

# Touchfree Counter Mounted System Installation Guide

## If there is a dispenser currently installed

- Remove the existing unit, both the above and below counter assemblies
- Clean the counter area where the previous dispenser was located
- Verify the size of the existing counter hole is 15/16" to 1-1/4" in diameter

## If there is no hole in the counter

- **Prior to drilling**, examine below the counter to ensure adequate clearance for the new unit
- Drill a 1" diameter hole in the counter top
- The hole can be drilled to either the right or left of the faucet, ensuring adequate clearance for the below counter assembly
- Clean the counter area where the new hole is located

## Installing the Touchfree Counter Mounted System

Prior to beginning installation, study the exploded view of the Touchfree Counter-Mounted System and locate all the pieces. Also, look beneath the countertop to find a suitable place for mounting of the Battery Box (9) so that it will not interfere with System components or plumbing.

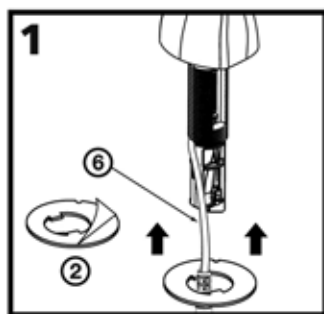

Remove the paper liner from one side of the Adhesive Gasket (2) to expose the adhesive. Feed the Data Cable (6) through the Gasket and slide the Gasket onto the threaded shank of the Dispenser Assembly (1), with sticky side toward the Dispenser. (Rotate the gasket until it follows the contours of the dispenser.) Press on the Gasket until it sticks to the bottom of the Dispenser. Then, remove the paper liner from the other side of the Gasket.

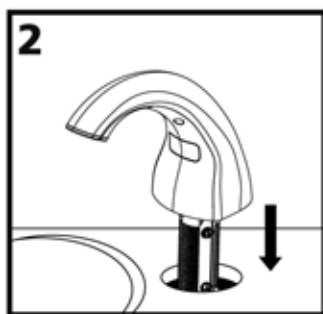

Feed the Data Cable (6) and the shank of the Dispenser Assembly (1) through the hole in the countertop. Point the spout of the Dispenser into the sink bowl and press down firmly on the Dispenser to securely attach it to the countertop.

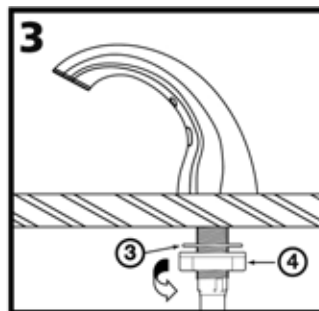

From underneath the counter, first feed the Lock Washer (3) and then the Mounting Nut (4) over the Data Cable (6) and onto the threaded shank of the Dispenser Assembly (1). Be sure that the "teeth" on the Washer will touch the bottom of the counter top and that the Nut threads easily onto the shank. (If the Nut is hard to turn by hand, it is upside down.) Hand-tighten the nut securely.

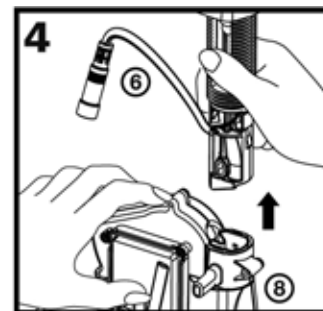

Align the indent inside the top of the Motor Assembly/Bottle Support (8) with the indent on the shank of the Dispenser Assembly (1) and firmly push the Motor Assembly/Bottle Support up, onto the shank.

**NOTE:** Hold the Data Cable (6) out of the way as you push up on the Motor Assembly/Bottle Support. Continue pushing upward until the vertical slots in the Dispenser Shank and the Motor Assembly/Bottle Support line up.

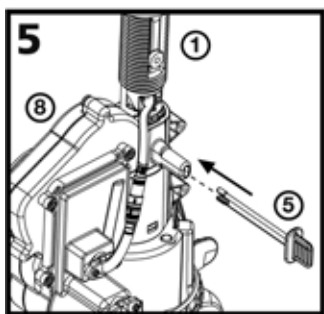

Secure the Motor Assembly/Bottle Support (8) to the Dispenser Assembly (1) shank by pushing the Retaining Clip (5) into place through the vertical slots, until it goes all the way through the Motor Assembly.

**NOTE:** The Clip may be inserted from either side.

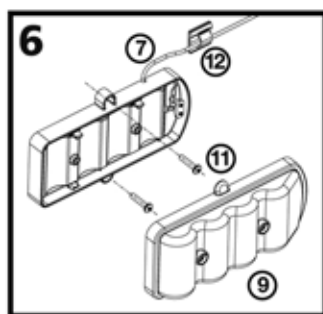

Remove the cover from the Battery Box (9) by loosening the two captive screws on the Battery Box cover. Position the Box on a convenient (vertical or horizontal) surface under the counter top that will allow access for battery changing. Attach the Box to the surface using the two screws (11) and anchors (if attaching to a plaster or masonry surface). Use the Wall Clip (12) to secure the Power Cable (7) to a wall or other under-counter surface if desired.

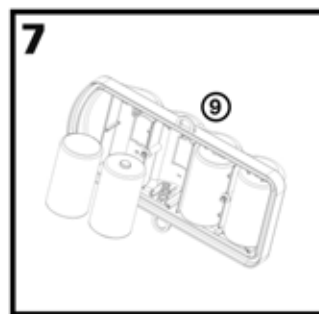

Place four alkaline "D" Cell batteries into the Battery Box (9) cover. The batteries must be positioned according to the diagrams shown on the inside of the cover.

**NOTE:** If the batteries are not properly installed or the cover is not properly positioned on the Box, the System will not work. Position the cover (with batteries installed) on the Battery Box and tighten the two captive screws.

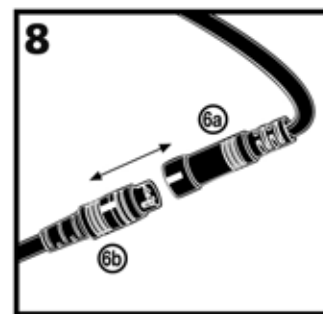

**IMPORTANT:** Connect the two halves of the Data Cable (6a) and (6b) by visually lining up the white stripes on each half and gently pushing the cable connectors together until the stripes touch.

**Improperly assembled connectors can cause unit to not function as intended.**

**NOTE:** After the batteries are installed in the Battery Box (9) and the two halves of the Data Cable are connected, it will take approximately 20 seconds before the Touchfree Counter Mounted System is ready to dispense soap.

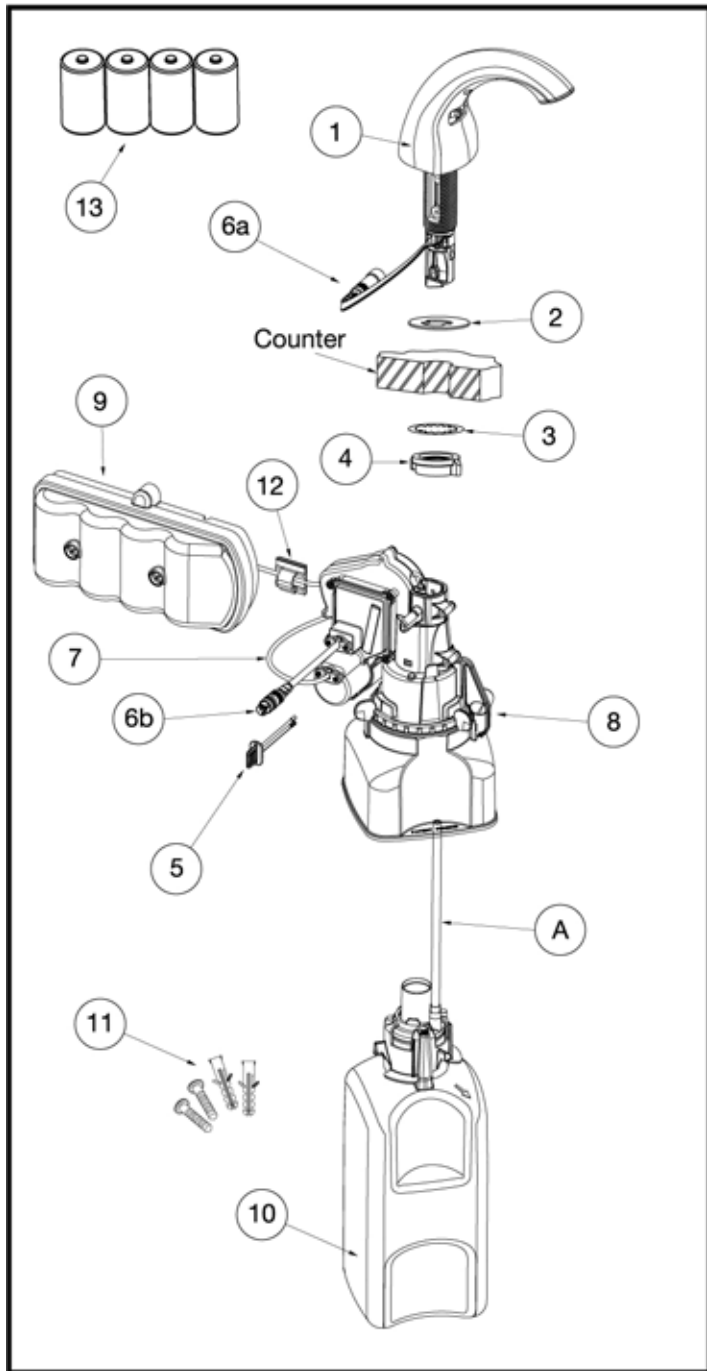

## Refill Installation (refill sold separately)

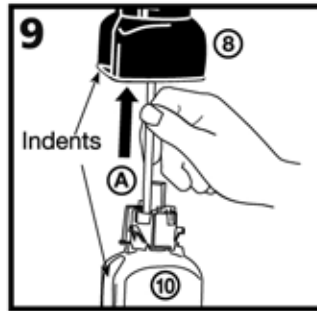

Feed the dispense tube (A) on the Refill Bottle (10) up through the Motor Assembly/Bottle Support (8) and Dispenser Assembly (1), aligning the two indents in the Bottle and the Support. Slide the Bottle upward until it snaps into place.

**NOTE:** The refill is not properly installed until you hear the "snap" (as the Green release latch on the Motor Assembly/Bottle Support (8) engages).

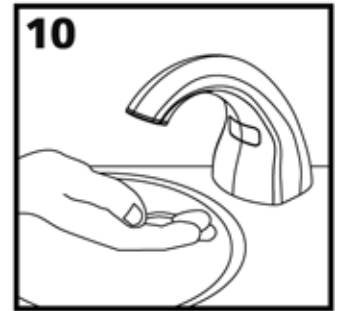

Test the System by passing your hand under the spout of the Dispenser Assembly (1) (in front of the sensor window) at least three or four times, until foam soap appears. If the System does not dispense soap after passing your hand in front of the sensor several times, repeat several more times. If no sound heard from motor assembly after placing hands in front of sensor, check to see that the Data Cable (6) halves are firmly connected, that the batteries are "good", and that the Battery Box (9) cover is properly positioned and fastened to the Box. Check for bent contact pins inside connector (6b). If unit is multi-activating, check for bent contact pins inside connector (6b).

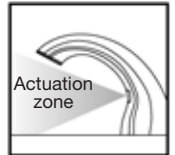

## Refill Removal

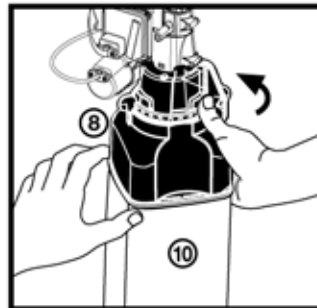

Grasp the empty Refill Bottle (10) with one hand and use the other hand to push the Green release latch on the Motor Assembly/Bottle Support (8) to the right (counterclockwise as seen from above).

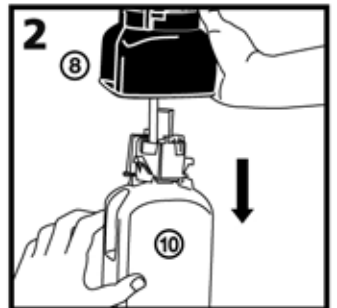

While still pushing the Green release latch, pull downward on the Refill Bottle (10) and remove it from the Motor Assembly/Bottle Support (8).

ITEM	DESCRIPTION	QTY.
1	DISPENSER ASSEMBLY	1
2	ADHESIVE GASKET	1
3	LOCK WASHER	1
4	MOUNTING NUT	1
5	RETAINING CLIP	1
6	DATA CABLE (2 HALVES WITH CONNECTOR - A and B)	1
7	POWER CABLE	1
8	MOTOR ASSEMBLY/BOTTLE SUPPORT	1
9	BATTERY BOX (USES 4 "D" CELL BATTERIES PROVIDED)	1
10	REFILL BOTTLE (SOLD SEPARATELY)	1
11	SCREWS & ANCHORS FOR BATTERY BOX MOUNTING	2 EA.
12	WALL CLIP FOR POWER CABLE	1
13	"D" CELL BATTERIES (PROVIDED)	4

## Cleaning the Counter Mounted System

Use only mild soap and water to clean the Touchfree Counter Mounted System spout. Cover the sensor window with your thumb while cleaning the spout so that you do not continue to dispense soap.

**DO NOT** use abrasives to clean the Touchfree Counter-Mounted System (since this may damage the finish or the sensor window).