

# 10', 12' & 14' Round Gazebo Floor Instructions

Revision: 9-08-03

Run:



Made in the U.S.A.

## - BEFORE YOU BEGIN -

Always wear OSHA-APPROVED safety glasses throughout assembly process

### ■ First...

Read these instructions thoroughly before you begin assembly. Assembly is easiest if you follow the steps in the order shown.

In a drawing, a dotted line represents a part hidden from view (like a part under a panel).

### ■ Check all parts

Compare parts you have to the list on page 2. If a part is missing, circle the part in question in the parts list and call us toll-free at 1-800-437-0784.

### ■ Preparation required

We recommend that you assemble this floor on level ground in the location it will be used. Assistance is necessary to handle, fit, and secure some components. Two people are needed for some steps.

### ■ Check local zoning

Before starting construction, check with your local building code official for any required permits, variances, etc.

### ■ Check Floor Kit Size

10' actual floor kit size is 9'-3" flat to flat or 10' in Diameter. 12' actual floor kit size is 11'-8-3/4" flat to flat or 12'-10" in Diameter. 14' actual floor size has to be a minimum of 14'-2" flat to flat or 15' Diameter is recommended.

## - TREATING YOUR GAZEBO -

### ■ Staining...

This Gazebo Floor Panels are constructed of a long-lasting western cedar. Untreated Cedar exposed to sunlight will eventually weather to a silver-grey color. To help keep original red color, applying of a minimum of two coats of oil based penetrating stain WITHIN 30 DAYS (required by warranty).

### STAIN REQUIREMENTS FOR GAZEBO FLOORS

FLOOR SIZE	# OF GALLONS
10'	1
12'	1
14'	1-1/2"

### ■ Tools required

- Hammer
- #2 Phillips Screwdriver
- Level
- Tape Measure
- Pencil

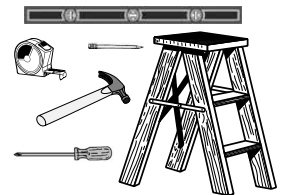

### ■ Optional tools

- Electric Drill w/ #2 Phillips Tip
- Nail Pouch

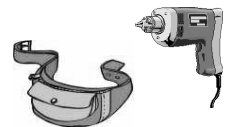

#16693

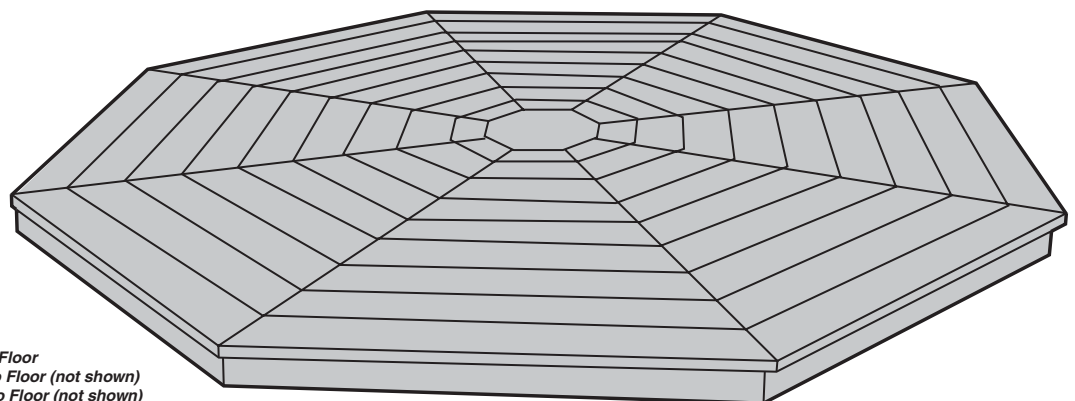

10' - 8 sided Gazebo Floor  
12' - 10 sided Gazebo Floor (not shown)  
14' - 12 sided Gazebo Floor (not shown)

# 10', 12' & 14' Gazebo Floor

8-Sided

10-Sided

12-Sided

## Parts List 10' Gazebo Floor Kit

- 8 pcs. J1's Treated 2 x 4 x 44-3/4"
- 8 pcs. J2's Treated 2 x 4 x 54-3/4"
- 1 pc. J3 Solid Center Block Treated 4 x 4 x 3-1/2"
- 1 pc. Base Plate Treated 2 x 8 x 7-1/2"
- 2 pcs. J4 Center Deck Face Cedar 1" x 10-5/8" x 10-5/8"
- 8 pcs. Pre-assembled Deck Panels Cedar
- 2-1/2" Screws, 3" Screws

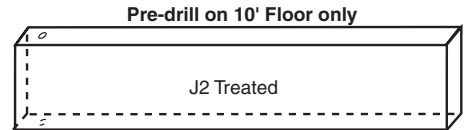

## Parts List 12' Gazebo Floor Kit

- 10 pcs. J1's Treated 2 x 6 x 44-3/4"
- 10 pcs. J2's Treated 2 x 6 x 67-7/8"
- 1 pc. J3 Hollow Center Block Cedar 6 x 6 x 5-1/2"
- 1 pc. Base Plate Treated 2 x 8 x 7-1/2"
- 2 pcs. J4 Center Deck Face Cedar 1" x 7" x 7"
- 10 pcs. Pre-assembled Deck Panels Cedar
- 2-1/2" Screws, 3" Screws, 6" screw driver bit

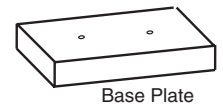
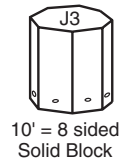
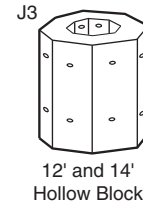
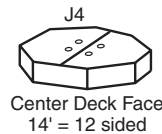
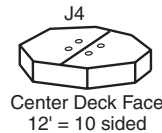
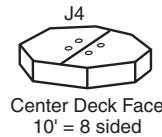

## Parts List 14' Gazebo Floor Kit

- 12 pcs. J1's Treated 2 x 6 x 44-3/4"
- 12 pcs. J2's Treated 2 x 6 x 81-1/16"
- 1 pc. J3 Hollow Center Block Cedar 8 x 8 x 5-1/2"
- 2 pc. Base Plate Treated 2 x 8 x 15"
- 2 pcs. J4 Center Deck Face Cedar 1" x 11" x 11"
- 12 pcs. Pre-assembled Deck Panels Cedar
- 2-1/2" Screws, 3" Screws, 6" screw driver bit

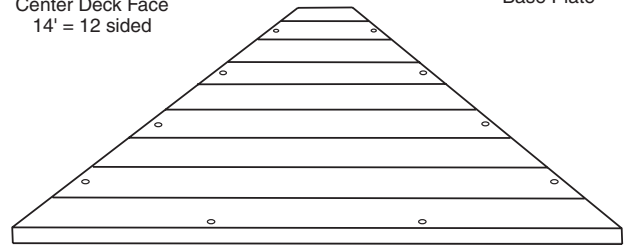

Pre-assembled Floor Panel  
10' = 8 sided  
12' = 10 sided  
14' = 12 sided

Note: Lumber is not marked with Part Letters Identification.

## NATIONAL STANDARD LUMBER SIZES

Nominal size	Actual size
2 x 4	= 1-1/2" x 3-1/2"
2 x 6	= 1-1/2" x 5-1/2"
2 x 8	= 1-1/2" x 7-1/2"

# 1 FLOOR SYSTEM ASSEMBLY

10' and 12' (1) Base Plate 2x8x7-1/2"  
14' (2) Base Plates 2x8x15"

For Soft Surfaces Only. If building your Gazebo floor on the ground, use your baseplate.

10' Gazebo Center Block Pre-Drilled  
Inside Holes Facing Up

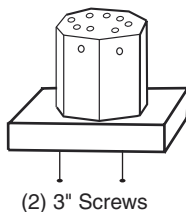

12' Gazebo Center Block Pre-Drilled  
Inside Holes Facing Up

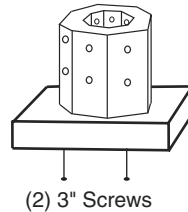

14' Gazebo Center Block Pre-Drilled  
Inside Holes Facing Up

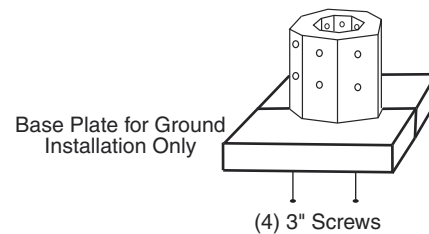

# 1

## FLOOR SYSTEM ASSEMBLY CONTINUED

### PARTS LIST 10' FLOOR KIT

□ 8 pcs.	J1's Treated	2 x 4 x 44- <sup>3</sup> / <sub>4</sub> "
□ 8 pcs.	J2's Treated	2 x 4 x 54- <sup>3</sup> / <sub>4</sub> "
□ 1 pc.	J3 Solid Center Block	4 x 4 x 3- <sup>1</sup> / <sub>2</sub> "

### PARTS LIST 12' FLOOR KIT

□ 10 pcs.	J1's Treated	2 x 6 x 44- <sup>3</sup> / <sub>4</sub> "
□ 10 pcs.	J2's Treated	2 x 6 x 67- <sup>7</sup> / <sub>8</sub> "
□ 1 pc.	J3 Hollow Center Block	6 x 6 x 5- <sup>1</sup> / <sub>2</sub> "

### PARTS LIST 14' FLOOR KIT

□ 12 pcs.	J1's Treated	2 x 6 x 44- <sup>3</sup> / <sub>4</sub> "
□ 12 pcs.	J2's Treated	2 x 6 x 81- <sup>1</sup> / <sub>16</sub> "
□ 1 pc.	J3 Hollow Center Block	8 x 8 x 5- <sup>1</sup> / <sub>2</sub> "

**NOTE:** Assembly shown below is for 10' Gazebo floor kit. The 12' and 14' Gazebo floor kit assembles in the same manner; however, there are two extra J1's, J2's and Deck Panels for the 12' and there are four extra J1's, J2's and Deck Panels for the 14'. Follow Instructions below for assembly of the 10', 12' and 14' floor kit.

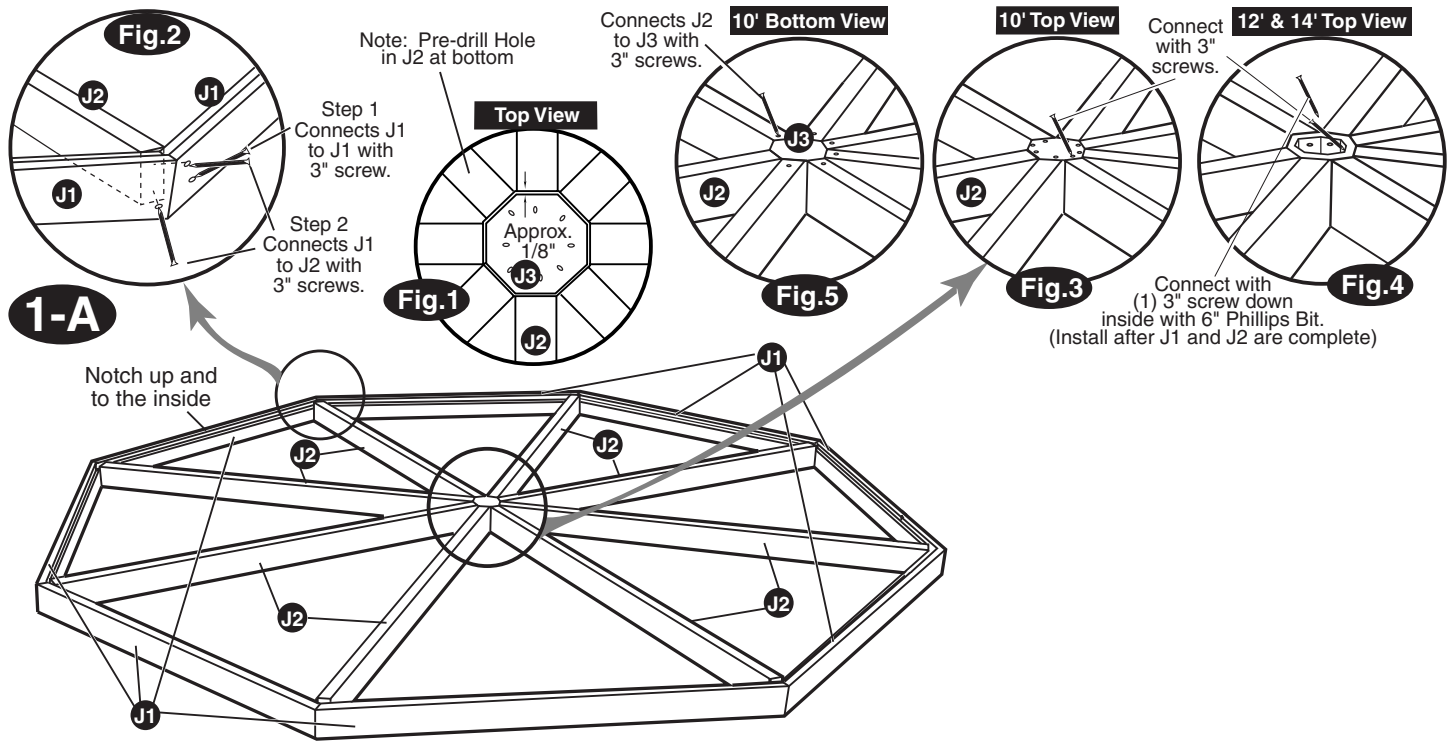

#### 1-A: Step 1

Locate the center of the area in which you will be setting up your Gazebo floor kit. Start with the J3 Center Block with the pre-drilled holes on top. Lay out eight J2's around block with the pre-drilled holes facing downward as in **FIG. 1** for 10' Gazebo, see **Fig. 4** for 12' and 14' Models. Attach with one 3" screw in each hole into J2's maintaining approximately 1/8" spacing between the J2's and J3 Center Block.

#### 1-A: Step 2

Layout all J1 parts on edge with the notch facing upward and inward at the end of the J2's forming a circular type pattern as shown in illustration above. Connect the J1's to J1's as shown in **Fig. 2** with one 3" screw. Be sure to keep all joints even at top and outer edges at the angle joint. Assemble remaining J1's in this same manner except for last pair of J1. Center the joint of the J1's in the center of the J2's as shown in Fig. 2 and attach the J1 to the J2 with two 3" screws as shown. Repeat this process to attach remaining parts. You should then be able to carefully close the final gap in the J1's. You may need to adjust the gap between J2 and J3 at this time.

#### 1-A: Step 3

**IMPORTANT:** Two people required for this step.

With all J2 boards secured to Center Block, **carefully turn the assembly over - 10' Gazebo only** and install one 3" screw through each predrilled hole in J2's into Center Block as shown in **Fig. 5**. You may have to remove Base Plate to install screws from the bottom on the 10' Gazebo Floor and reinstall. If Installing a 12' or 14' Gazebo floor, do not turn floor over. Install remaining 3" screws into Center Block with 6" bit supplied in kit as shown in **Fig. 4**.

# 1

## FLOOR SYSTEM CONTINUED

### PARTS LIST 10' GAZEBO

- 8 pcs. Deck Panels
- 1 pc. J4 Center Deck Face

### PARTS LIST 14' GAZEBO

- 12 pcs. Deck Panels
- 1 pc. J4 Center Deck Face

### PARTS LIST 12' GAZEBO

- 10 pcs. Deck Panels
- 1 pc. J4 Center Deck Face

## 1-B

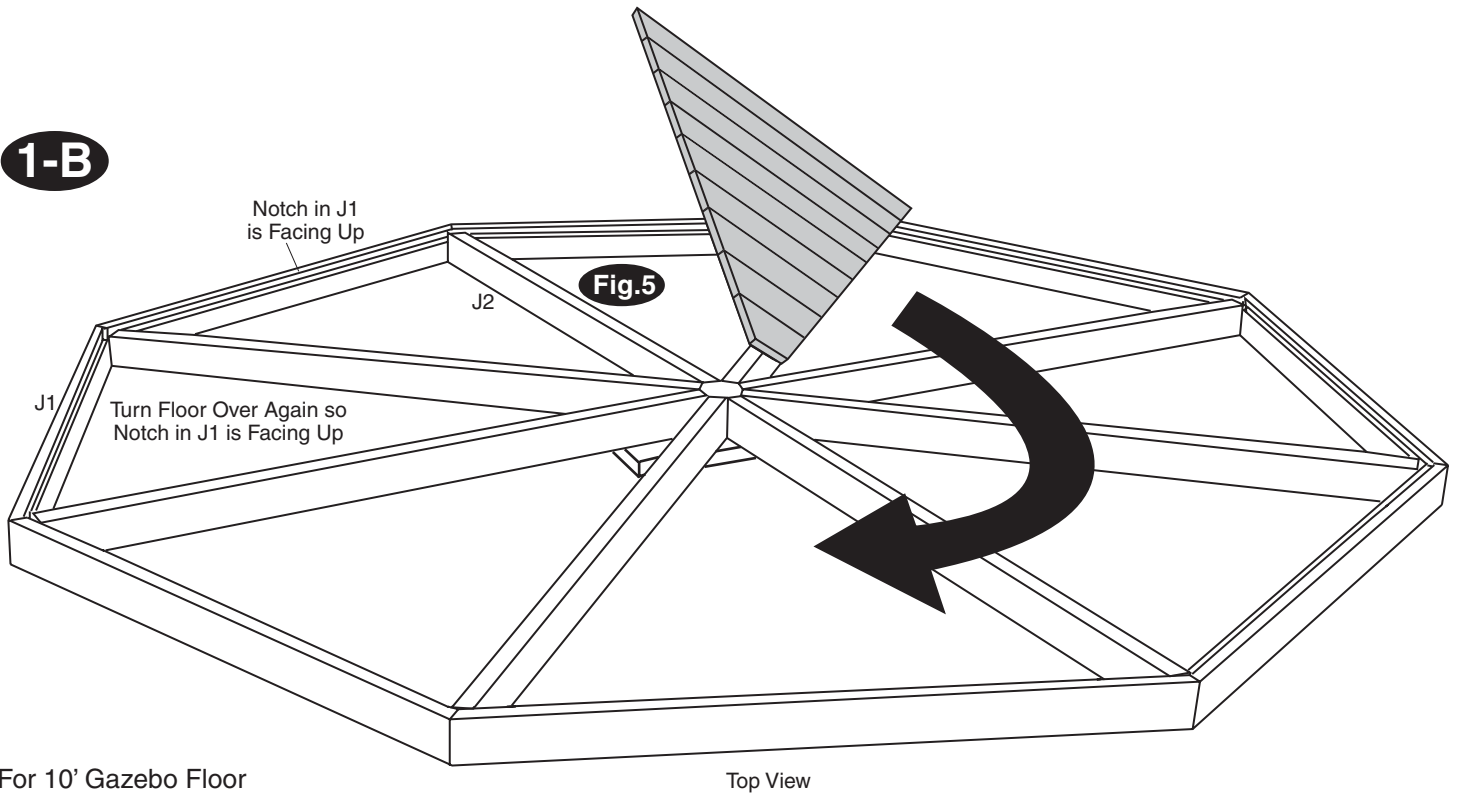

For 10' Gazebo Floor carefully turn floor over again so notch is facing up.

### 1-B: Step 1

Starting in one section, CAREFULLY set Floor Panel in place as shown in illustration above **Fig. 5**. Align Floor Panels so that they are equally spaced. DO NOT attach to J2's! Seams should line up directly over center of J2's. HINT: If last Floor panel does not fit as desired, slightly back out screws attaching J2's to J3 Center Block. Once in place, you may snug screws needed to back out for tight fit. With all edges and seams and edges aligned as desired, attach Floor Panels through the pre-drilled holes using 2-1/2" screws. Locate Center Deck Plates J4 and align in center opening keeping spacing equal on all sides and attach with 2-1/2" screws as shown in **Fig. 6**.

