



5/5/2006

VISIT THE LIFETIME WEB SITE:
WWW.LIFETIME.COM

**** Do Not Contact the Store ****
For Assistance, including missing or broken parts,
Call Customer Service at:
1 (800) 225-3865

14" x 30" Shed Shelf Kit w/ 5 Shelves
MODEL #0115

ASSEMBLY
INSTRUCTIONS AND
OWNER'S MANUAL

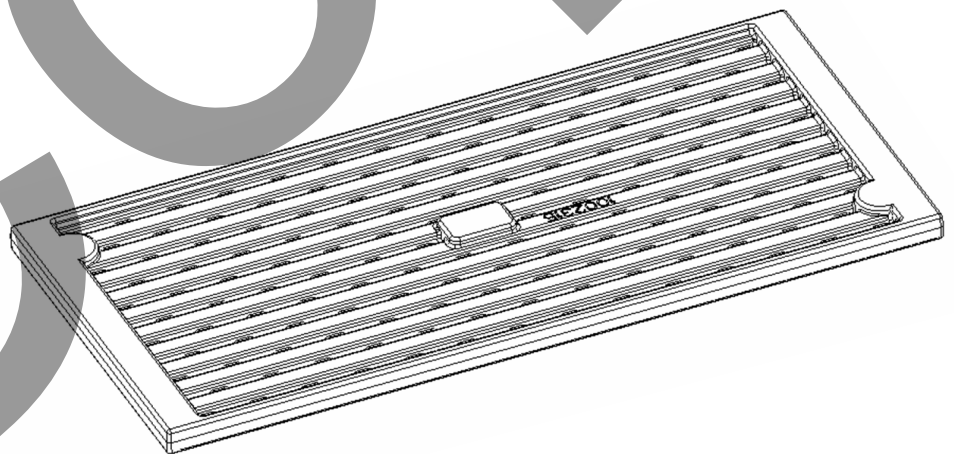

Save this instruction in the event that the manufacturer has to be contacted for replacement parts.

INSTRUCTION #1011558

STOP!

BEFORE BEGINNING ASSEMBLY

STOP!

Identify and inventory all parts using the checklist boxes on the Parts List. Keep the hardware bags and their contents separate. If any parts are missing, call our Customer Service Department.

PARTS LIST

AA	1009352	14" Shelf	5
AB	1009119	14" Shelf Bracket	10
Shelf Hardware Bag [1011394]			1
SA	1009115	Back Shelf Support	5
SB	BS05900	#10 x 1/2" Pan Head Screw	36
SC	BW01300	#10 Washer	21

AA

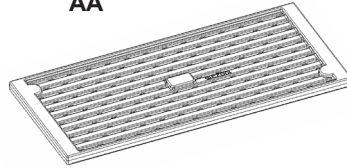

AB

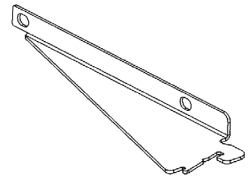

SA

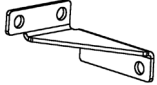

SB

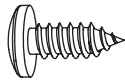

SC

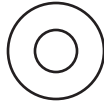

1 Shelf Installation

1a Insert Shelf Brackets (AB) into notches in any Wall Support Channel. Place the Shelves on brackets and secure with #10 screws (SB) and #10 Washers (SC).

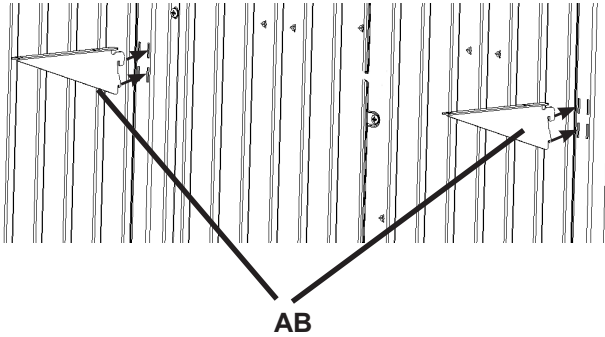
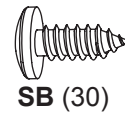

Insert Brackets into the inside set of slots on the Wall Channels. Otherwise Brackets will be too far apart to support shelves.

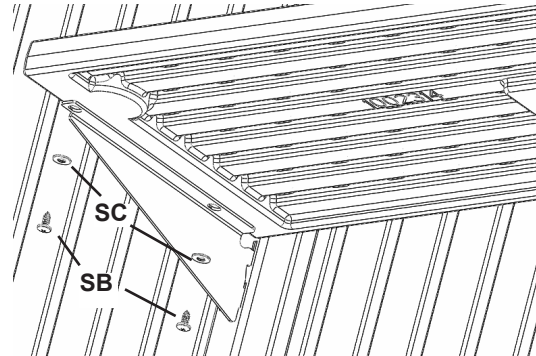

1b Install a Back Shelf Bracket (AB) to each Shelf with a #10 screw (SB). Line up the Bracket so that it will connect to the wall in between grooves. Attach it to the bottom of the shelf. Then screw the Bracket into the wall.

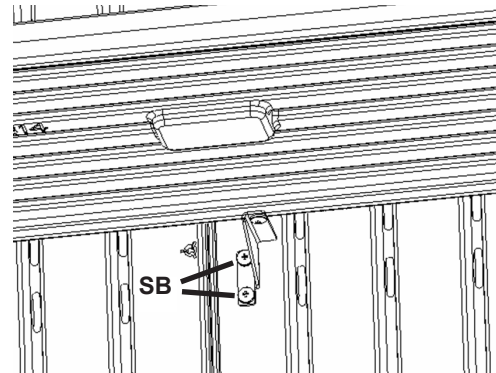
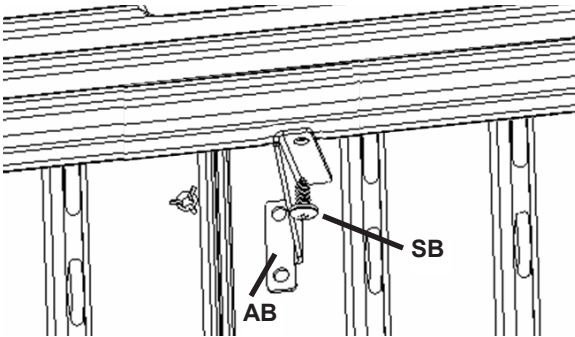

Alternate Shelf Location

1c Shelves may also be installed in between trusses to provide overhead storage. Rest a shelf between two trusses. Attach shelf to Truss Channels through slotted holes in channels.

The shelves fit length wise inbetween the Trusses.

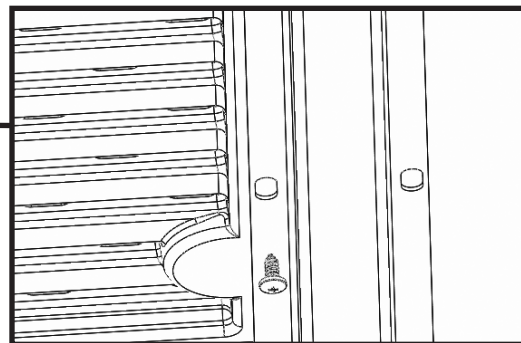
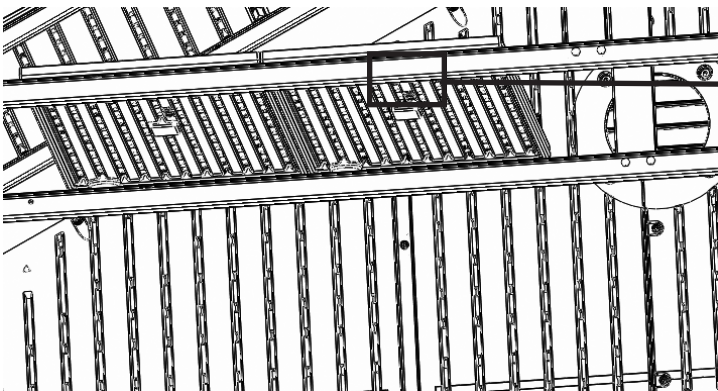

Note: This is an interior upward view.