



ASSEMBLY INSTRUCTIONS **ROUND STYLE 30X30X15**

Please read instructions completely before you begin. This will help attain the best results for your installation.

CONGRATULATIONS!

Congratulations on your purchase of a MDM Products 30x30x15 Round Style Portable Building. With proper installation, use and maintenance, your new unit will provide many years of good and suitable service. Your new MDM Products portable enclosure is a combination of excellent engineering and well thought out design. The unit is comprised of a rigid tubular frame, covered with a long life polyethylene cover and double door ends.

The multiple part frame assembly is pre-drilled for easy insertion of frame bolts. The tubing is made from high-grade galvanized steel., resisting moisture and oxidation over the life of the shelter. The cover and doors are made from **ASTM-5** approved polyethylene materials. The cover is UV protected for exposure to sunlight.

SAFETY WARNING

The installation of this unit must conform to the requirements of all authorities having jurisdiction in your specific local area. In the absence of such requirements, the assembly and installation must conform to the provided assembly and installation instructions. MDM Products, LLC will not responsible for failure to comply with any requirements in a given local area. Damages, consequential damages, or injuries caused by improper installation, alteration, improper use, or damages caused by snow, wind, or any acts of nature are strictly that of the user. Unit is not intended for occupancy for any length of time. NO running of internal combustion engines, open flames or contact with heated surfaces is allowed.

For installation assistance or Customer Service, please call 800-447-7079 or 203-877-7070, 8AM-5PM EST. Cartons should be inspected upon delivery from carrier, and any evident damages should be noted on the bill of lading before signing. If upon opening the cartons hidden damage is discovered, contact carrier or it's agent

immediately. Claims for shipping damage MUST be made with the shipping company. An inspection of the goods will most likely be required. Do not discard packing or any components before the freight company inspection. All claims for freight damage must be made within 15 days of receipt of the goods in accordance with ICC regulations.

ASSEMBLY PROCEDURE

The proper sequence and steps to install this unit will produce a proper and good installation. Failure to read and follow these guidelines may result in an improper installation and will void all warranty and protection the owner is entitled to with the product. The steps to be undertaken are:

1. Perform an inventory check before beginning, to be certain all components are available for installation.
2. Prepare location and place all unit boxes near location sight.
3. Assemble Seven (7) Arch Assemblies of unit.
4. Assemble unit End Arch, first Interior Arch, and Wind Braces with the first ridge crest, base, and side rail sections.
5. Add additional Arch Assemblies with each section of base rails and side rails.
6. Level and square Frame of Unit.
7. Anchor frame assembly to ground with provided anchors, U-bolts and drive rod.
8. Install Doors (2) on ends of frame assembly.
9. Install Main Cover over frame assembly.
10. Install Door Roll-up kits

TOOLS REQUIRED











The following hand tools will be needed for proper installation of your new MDM Products building:

- 9/16 Open End Wrench
- 9/16 Socket or Box Wrench
- Large Flat Head Screwdriver
- 2lb maul or Sledgehammer
- 2 Foot Level
- 12' Step Ladder
- Stakes & String for squaring Frame

INVENTORY CHECK

Start installation procedure by removing all components from packaging to ensure all components are present. Inventory chart appears on the last page of this manual.

Frame Parts

| | | | | | |
|---|---|--|--|---|---|
|  <p>#1 / CT-7006 Arch Crest Tube Swedged one end Used to construct arch</p> |  <p>#2 / CT-7007 Arch Crest Tube Plain ends Used to construct arch</p> |  <p>#3 / CT-7008 Arch Side Tube Swedged one end Used to construct arch</p> |  <p>#4 / EUL-7002 Arch End Upright with foot. Use on End Arches and Center Arch.</p> |  <p>#5 / EUL-7003 Arch End Upright plain. Use on Arches #2,#3 and #5,#6</p> |  <p>#6 / CWB-7005 Corner Wind Brace Both ends flat. Use on four corners of unit</p> |
|  <p>#7 / ECR-7003 End Cross Rail piece Plain Ends. This is the first or last piece of the Cross Rail.</p> |  <p>#8 / SCR-7004 Cross Rail piece Swedged Ends. Connect to End Cross Rail piece, and together to form entire Cross Rail.</p> |  <p>#9 / EP-1001 1" End Plug Use on ends of Cross Rails.</p> |  <p>#10 / EP-1003 2-3/8" End Plug Use on ends of Arch Foot.</p> | | |

Hardware

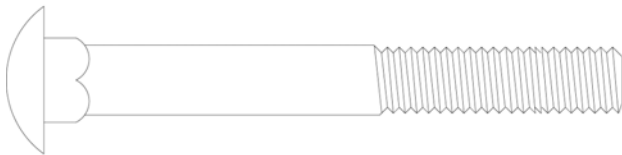

#11 / CBN-7005-4
3/8" x 4" Carriage Bolt
Used on Arches and Cross Rails



#12 / CBN-7005-CW
3/8" Curved Washer
Used on Arches and Cross Rails
When 4" carriage Bolt is used

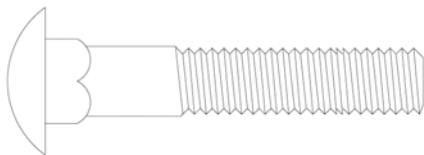

#13 / CBN-7005-4
3/8" x 2-7/8" Carriage Bolt
Used to connect Upright Foot and
Plain Upright to Arch.
Also on Wind Brace to Corner Foot.



#14 / CBN-7005-W
3/8" Flat Washer
Used where Wind Brace connects
to frame.



#15 / CBN-7005-N
3/8" Locknut
Used on entire frame with
Carriage Bolts

NOTE: Carriage Bolts should always be inserted from the outside of the frame, pointing in toward the interior of the frame. This will prevent the bolts from puncturing through the main cover or doors.

Complete Frame Assembly

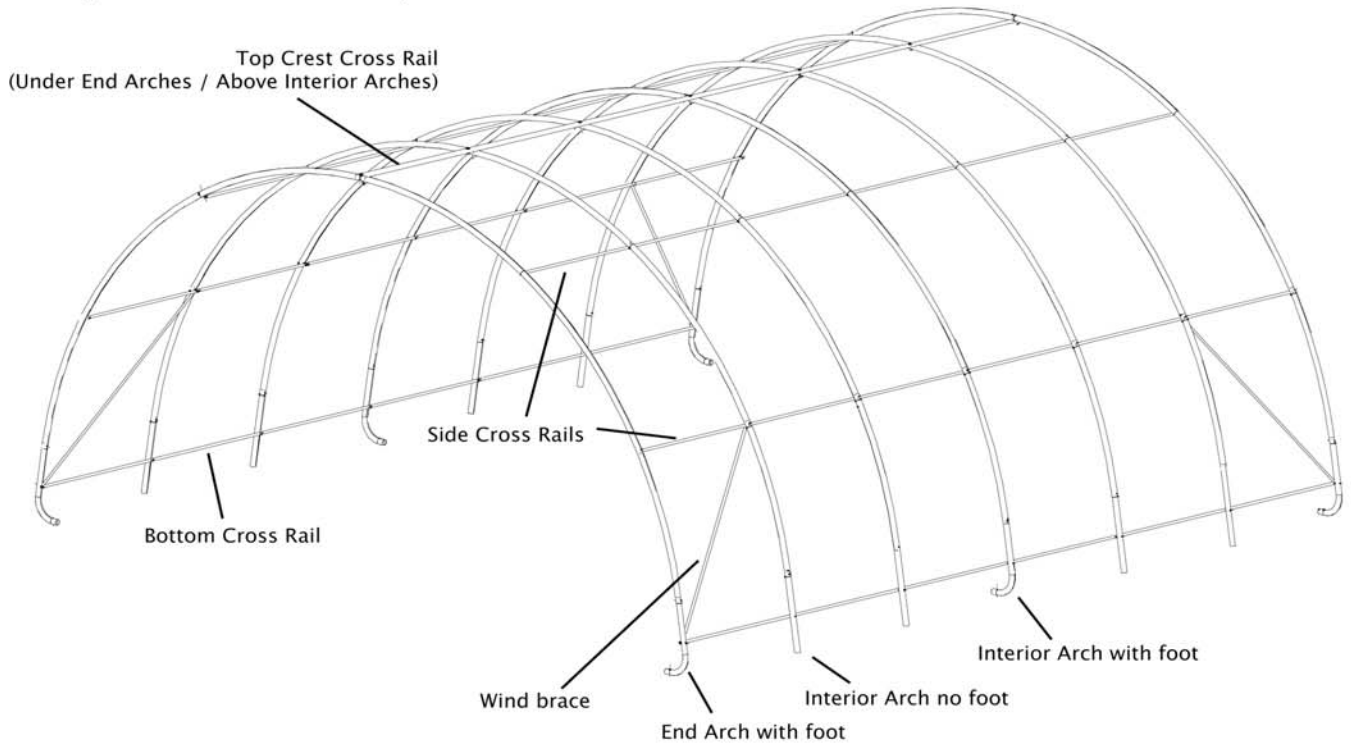

Top part of Arch Assembly (detail)

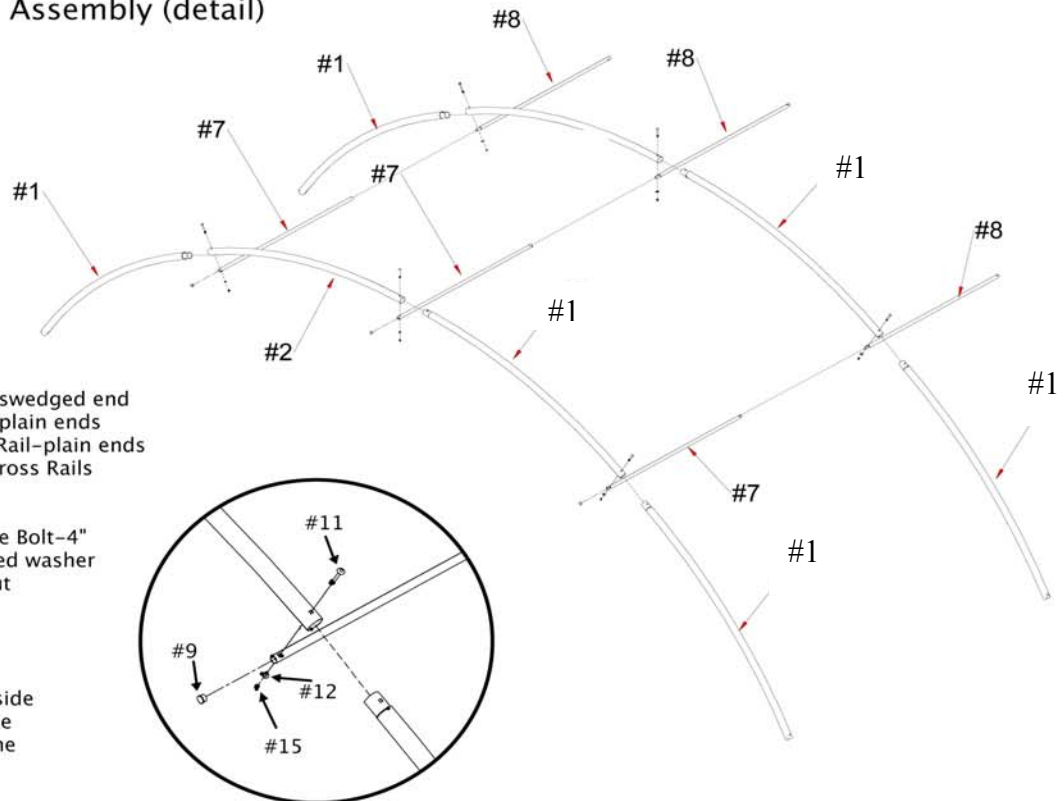

- #1 - CT-7006 / Crest Tube-swaged end
- #2 - CT-7007 / Crest Tube-plain ends
- #7 - ECR-7003 / End Cross Rail-plain ends
- #8 - SCR-7004 / Swaged Cross Rails

Hardware

- #11 - CBN-7005-4 / carriage Bolt-4"
- #12 - CBN-7005-CW / Curved washer
- #15 - CBN-7005-N / Locknut
- #9 - EP-1001 / End Plug-1"

Note: Carriage bolts should always be inserted from the outside, pointing towards inside of frame. This will prevent the bolts from poking through the cover and doors.

Bottom Portion of Arch Assembly (detail-right side)

- #3 - CT-7008 / Arch side Tube-swaged
- #4 - EUL - 7002 / Arch End Upright with Foot
- #5 - EUL - 7003 / Arch End Upright-plain end
- #6 - CW - 7005 / Corner Wind Brace
- #7 - ECR - 7003 / End Cross Rail piece-plain end
- #8 - SCR-7004 / Cross Rail piece-swaged

Hardware

- #11 - CBN-7005-4 / carriage Bolt-4"
- #12 - CBN-7005-CW / Curved washer
- #13 - CBN-7005-3 / Carriage Bolt-2 7/8"
- #14 - CBN-7005-W / Flat Washer
- #15 - CBN-7005-N / Locknut
- #9 - EP-1001 / End Plug-1"
- #10-EP-1003 / End Plug-2 3/8"

Note: Carrige bolts should always be inserted from the outside, pointing towards inside of frame. This will prevent the bolts from poking through the cover and doors.

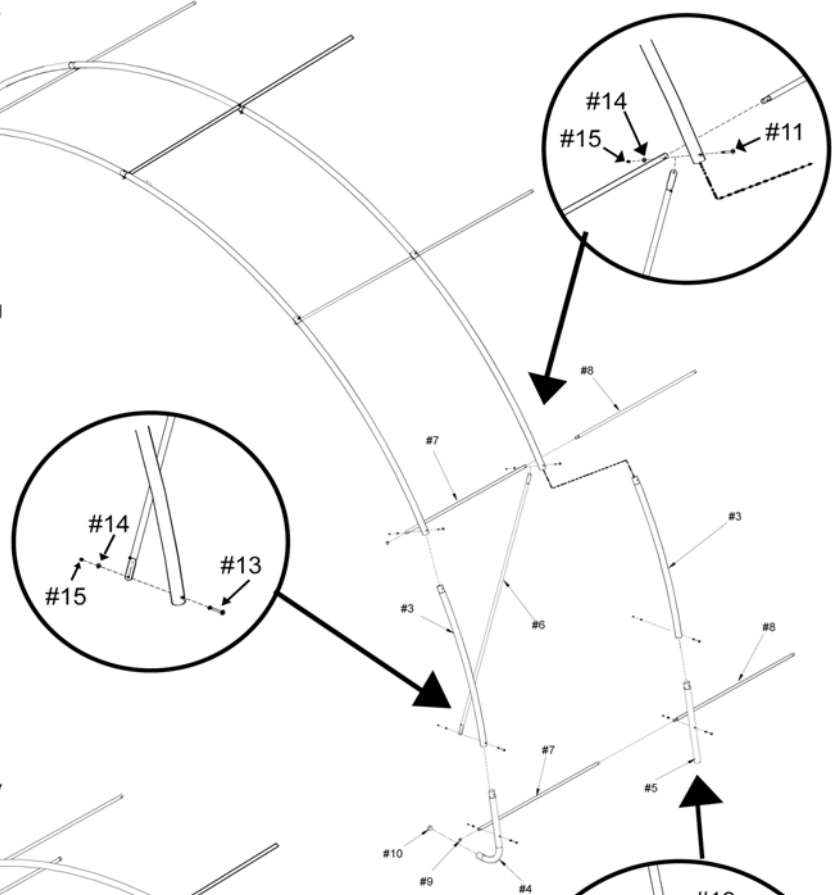

Bottom Portion of Arch Assembly (detail-left side)

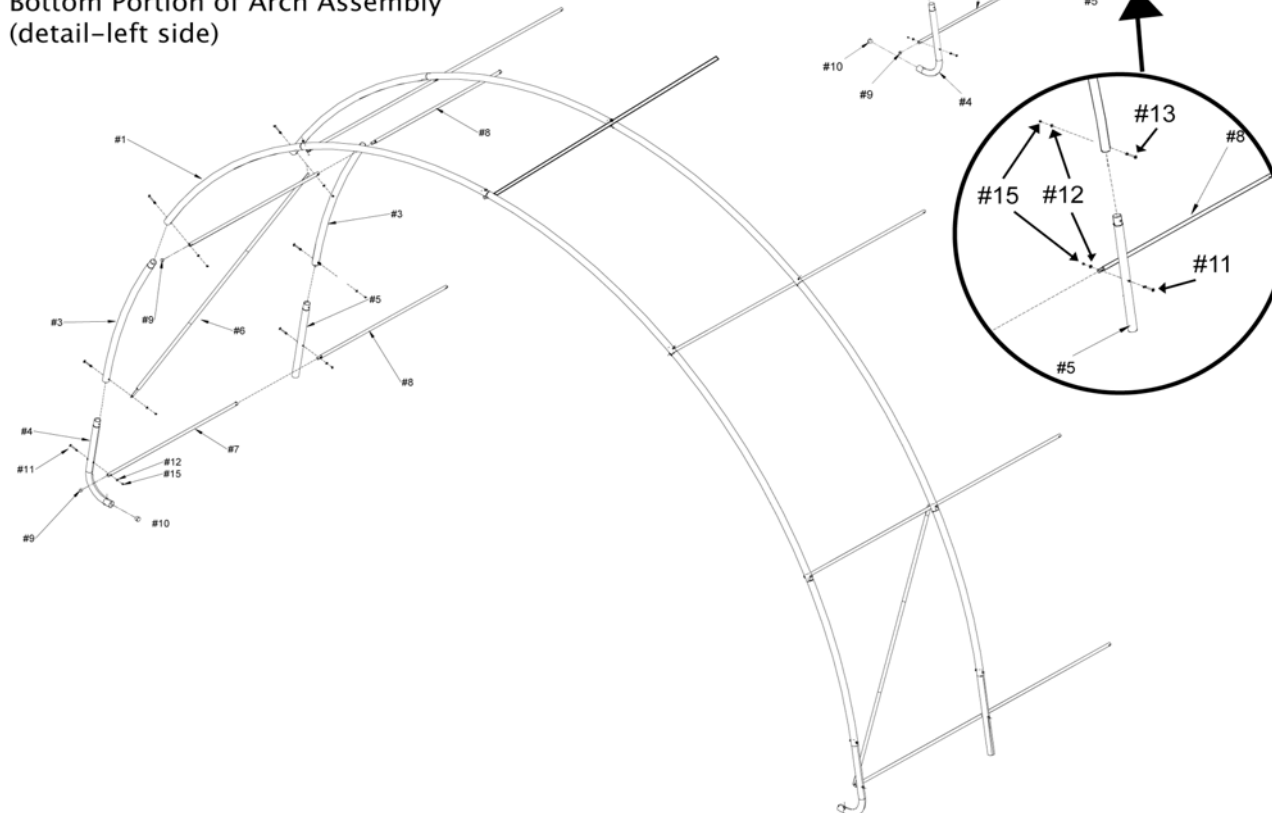

SITE PREPARATION

Select a level or as close to level as practical location for your MDM Products Building. The building should be placed on a base of materials suitable for the storage load to be protected. The unit should not be located under trees, which will shed hard fruit such as apples, walnuts, or heavy pine cones. The cover of your unit will protect against normal falling leaves and light debris, however, large branches or other falling items may cause a puncture or tear in the cover material.

Take notice of drainage around your intended location. Water draining from the surrounding terrain should be planned so that it does not run into the unit. As well, rain or melting snow hat comes off the unit should be drained away rather than accumulate and pool around the unit. Check to be certain that adequate clearance is allowed for entry and exit from ends of the unit. As unit has doors on both ends, ideally boat or equipment can be inserted or removed from either end.

Using the stakes and string, measure off and square area for intended installation. Level the ground as best as possible.

A properly leveled frame yields maximum strength.

ARCH AND FRAME ASSEMBLY

Step 1. ASSEMBLE THE FRONT & REAR END ARCHES AND #4 MIDDLE ARCH W/FEET (3 ARCHES)

Each **ARCH** consists of:

- 3 - #1 CT-7006 Crest Tube-swedged end
- 1 - #2 CT-7007 Crest Tube-plain ends
- 2 - #3 CT-7008 Arch Side Tube
- 2 - #4 EUL-7002 Arch End Upright with Foot

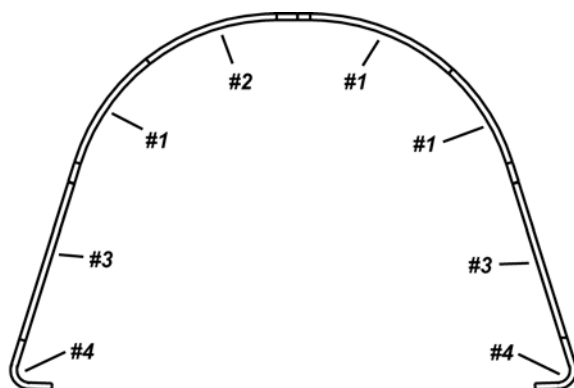

End Arch (and #4 arch) Assembly

Use **Carriage Bolts with Washers and Nuts** through pre-drilled holes in frame members. (refer to detail of arch assembly for correct hardware) Be certain to insert

carriage bolts from the outside into the interior of the unit, with the washers and nuts on the inside of the frame. This will prevent the bolts from puncturing through the cover material. Do not tighten down the nuts completely until frame is fully assembled and set in place.

Step 2. ATTACH CORNER WIND BRACES TO FRONT AND REAR END ARCHES

Attach Corner Wind Braces #6 CW-7005 to the **INSIDE** of EACH side of the End Arches you assembled in step 1. Refer to detail drawing for correct hardware. Do not tighten completely.

Step 3. ASSEMBLE THE REMAINING (4) FOUR INTERIOR ARCHES

Each **INTERIOR ARCH** consists of:

- 3 - #1 CT-7006 Crest Tube-swedged end
- 1 - #2 CT-7007 Crest Tube-plain ends
- 2 - #3 CT-7008 Arch Side Tube
- 2 - #5 EUL-7003 Arch End Upright –plain base

Use Carriage Bolts with Washers and Nuts through pre-drilled holes in frame members. Refer to detail drawing for correct hardware. Be certain to insert carriage bolts from the outside into the interior of the unit, with the washers and nuts on the inside of the frame. Do not tighten down the nuts completely.

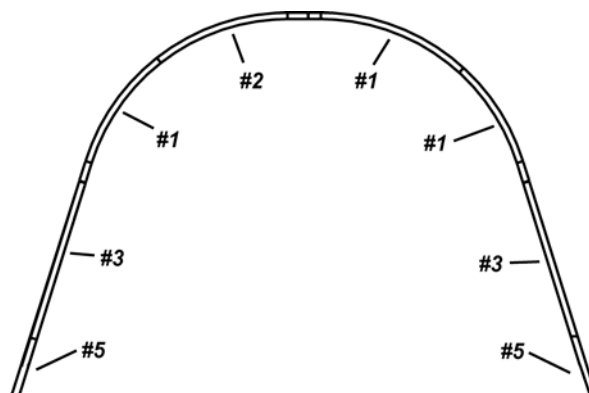

Arch Assembly, for arches #2, #3, #5, #6 (Arches without foot)

Step 4. START COMBINING ARCH SECTIONS TO BUILD FRAME

Stand first End Arch Assembly up and support with the wind brace temporarily. Attach #7 ECR-7003 Plain End

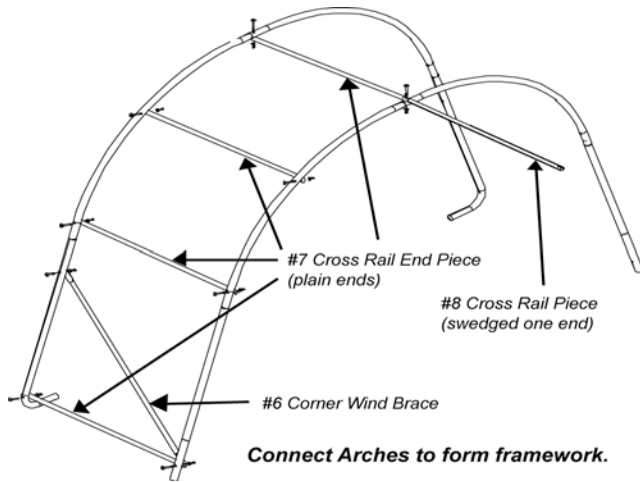

Cross Rails to the inside of the End Arch Assembly using 4" Carriage bolts, washers and nuts through the pre-drilled holes. Again do not tighten down completely. Always remember to insert bolts from the outside into the interior to prevent damage to cover.

Begin the Top Ridge Crest Cross Rail by placing the first end UNDER the End Arch Assembly, secure loosely with carriage Bolt CBN-7005-3, with washer and nut facing interior of unit.

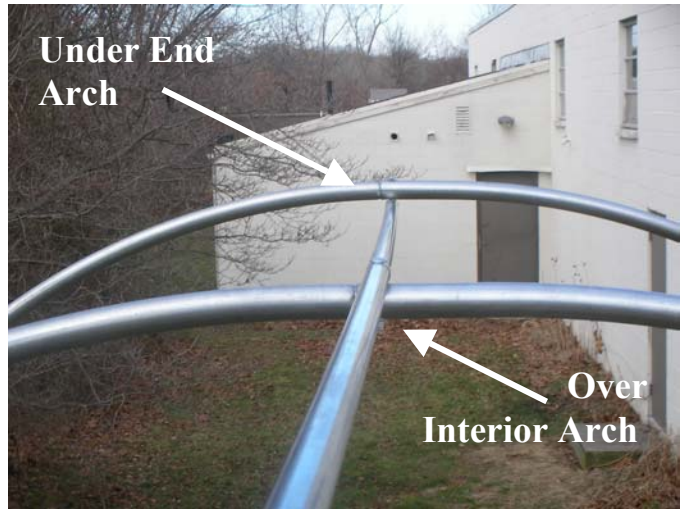

Step 6. CONNECT ADDITIONAL ARCHES

Add Interior Arch Assembly #3 to the first two arches assembled in Step 4. The Top Ridge Crest Cross Rail (only) will be UNDER the End Arches and OVER the Interior Arches (see Illustration). All the other Cross Rails will be on the inside of the frame. Interior Arch Assembly #4 (Middle Arch) with feet is put on in the middle of the frame support.



Stand an Interior Arch Assembly (without feet) assembly into place about 60" from end arch assembly. Align holes in Arch with Cross Rails. Using 4" Carriage Bolts, with nuts and washers connect the Side Cross Rails between the arches. Connect Wind Brace from End Arch Assembly To first Interior Arch. This will make the first two arches self-supporting. Insert next Cross Rail into the base and Side Rails for the next arch assembly.



Interior Arch Assembly #5 and #6 have plain feet ends. The last Arch #7 will be the remaining End Arch Assembly with feet. Make certain to install the Wind Braces between the End Arch Assembly (#7) and the first Interior Arch Assembly (#6) to complete the frame assembly.

DO NOT completely tighten down bolts that connect the Cross Rails to the END ARCHES, they must be removed for End Panel Zippered Door Installation.

Step 5. TOP RIDGE CREST CROSS RAIL

Version 2.0

Please **DO NOT** return unit to store or dealer. For all questions or shortages please contact Customer Service at: 800-447-7079 or 203-877-7070

Step 7. LEVEL AND SQUARE FRAME

Align the first side of the building arch assemblies using a string. This should be the permanent position desired for the building.



Measure the base span of each arch, side to side. The outside of the arch bases should be 30'. Too wide a span will weaken the frame resistance to load, such as

snow, and prevent the doors and main cover from fitting properly. Adjust each arch to the correct width, using the first side aligned above.

Measure diagonally from inside corner to inside corner of frame. Both diagonal measurements should match. Adjust frame and support as necessary to bring frame into square. Failure to square frame will result in poor cover fit and reduced strength and rigidity. Frame should be 30' side to side and 30' front to back – Outside Dimensions.

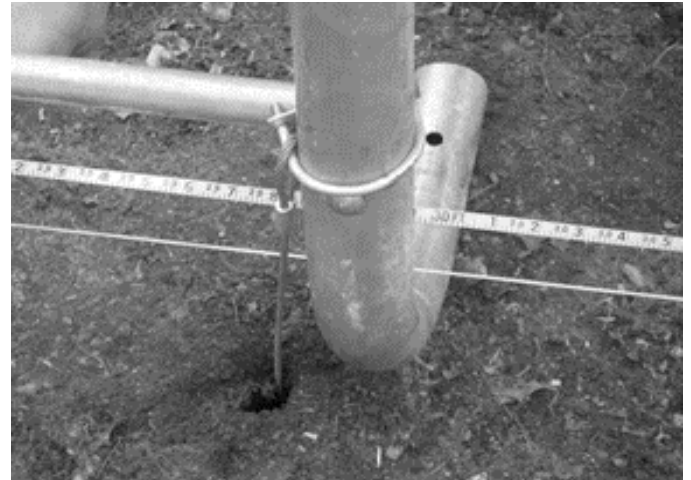

30' Length and 30' Width Outside Dimensions



PROPER BASE SUPPORT

The weight of the building will rest on the base of the arch uprights and feet. If the ground is not hard, support the legs with a patio block or brick to prevent sinking into the earth or settling afterwards.

Version 2.0

Please DO NOT return unit to store or dealer. For all questions or shortages please contact Customer Service at: 800-447-7079 or 203-877-7070



MAINTAINING FRAME POSITION

To help hold the frame in place and square, insert a piece of rebar or landscape stake into the hole in the end and center arch feet into the ground. This will help keep the frame square, and prevent the ends from spreading and straining the zippered doors.



Step 8. TIGHTEN CARRIAGE BOLTS

Once frame is square and leveled and properly supported, tighten down carriage bolts. Do NOT over tighten. Do not oval or otherwise crush tubing pieces. Do not tighten cross rails on end arches or wind braces until after doors are assembled.



Insert PLASTIC END PLUGS #EP-1000 & #EP-1001 into all open ends of frame members.

ANCHORING FRAME TO GROUND

NOTE: Frame must be anchored before installing any doors or cover.

Each MDM Products 30x30 building comes with 14 DUCKBILL CABLE ANCHORS (DBA-3000) with U-bolts and nuts. These versatile anchors allow the frame to be secured to almost any surface. In addition a 36" DRIVE ROD (DR-3001) is included to drive the anchor heads into the earth.

Anchor placement should be on the inside of the unit, at each corner and at the base of each upright leg pole. This will prevent unit frame from spreading over time.



STEP 1.

Place DRIVE ROD into the cup of the anchor head. Using a heavy hammer, drive the anchor into the ground until 6-8 inches of cable remain above the ground. Remove drive rod.

STEP 2

Wrap the cable three times around the drive rod and pull upward to set the anchor in place.

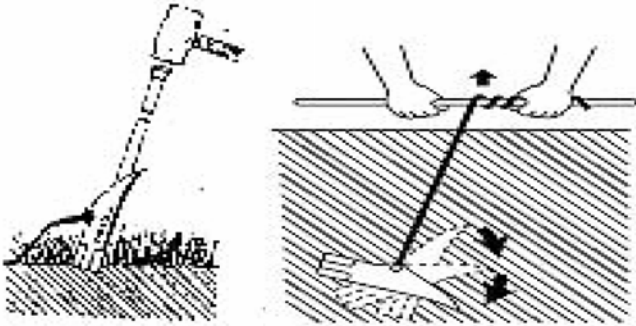

STEP 3

Slip one side of the U-bolt through the eyelet at the end of the anchor cable. Attach the cable to the leg upright with the U-bolt and tighten. Ensure there is no slack in the cable. Slack can be removed by wrapping the cable around the tie-down rail.

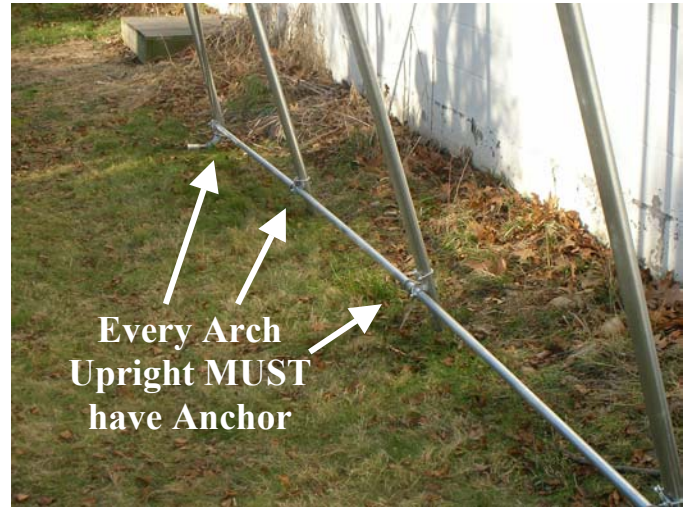

End Panel / Doors have pre-cut slots that allow Cross Rails to pass through, so material can wrap around arch with rope pocket inside unit

END PANEL/ZIPPERED DOOR INSTALLATION

NOTE: End Panel/Doors **MUST** be installed **BEFORE** Main Cover. Also required for Building Strength.

STEP 1. PREPARE FRAME MEMBERS

Remove the Carriage Bolts holding the Top Crest Cross Rail and Side Cross Rails to the End Arch. (these are the ones you left loose). Bring the Door Panel up to the outside of the frame arch, keeping the white side in, colored side out. Align the material evenly over the arch so bottom is slightly off ground.

STEP 2. ATTACH END DOOR PANEL

Wrap the edges of the panel around the frame arch, bringing the slits in the panel, to the inside of the frame.

Thread the Top Ridge and Side Cross Rails through the slits and re-attach to the frame arch using carriage bolts,

with nuts and washers facing inward as always. Tighten down.

Each End Panel/Door will also require removal of Wind Brace bolts, and placement of Wind Brace through slits in End Panels. Remember to reconnect Wind braces with carriage bolts and tighten down, once End Panel is in place.



Tie off that end of the rope to a turnbuckle (fully opened) attached to that Corner Foot. The End Panel / Door can then be tightened further by adjusting the Turnbuckles.

NOTE: Adjust the end panel / door by turning the turnbuckles or repeating step 3 till taut.



STEP 3. TIGHTEN AND SECURE END PANEL/DOOR

Tie off one end of the rope coming out of the end panel to a TURNBUCKLE (turnbuckle should be loosened all the way), and attach the turnbuckle to the hole in the Corner Foot of the End Arch. Grab the other end of the rope and apply downward pressure with your foot to tighten the fabric around the arch and remove excess slack. Re-adjust gathered material evenly along frame arch, this step is key to getting a good door fit.

Adjust the door panel so that the edges do not come in contact with the ground. Cut the Slits as Needed To Adjust the Door Edge Off the Ground. Put an Electrical EMT or Pipe into the bottom edge to put weight on the door fabric.

Repeat Installation for other End Panel / Door.



The Rope Pocket should be located inside the unit with frame members passing through the pre-cut slots. Replace carriage bolts after putting the end panel in place.

When putting on the doors, adjust the length to make certain the doors do not drape onto the ground. If pulling them up puts too much stress on the slit where it goes over the wind brace, use a sharp knife to cut slit another inch or two to relieve it. The PE fabric is rip-stop weave, and can easily be cut to relieve stress at the frame members.

MAIN COVER INSTALLATION

STEP 1. To elongate the life of Main Cover, put a small square of duct tape (field supplied) over each bolt head on frame that comes in contact with cover. The tape acts as a cushion to avoid rubbing damage to the cover over years. As an alternative, foam rubber pipe insulation makes a good cushion between the bolt heads and the main cover as well.



STEP 2. POSITION COVER ON FRAME

Version 2.0

Please DO NOT return unit to store or dealer. For all questions or shortages please contact Customer Service at: 800-447-7079 or 203-877-7070

Unpack the MAIN COVER (RUC-0000) from the protective plastic packaging. Place the Cover along the Outer Edge of the frame on one Side. The Cover should be parallel to the frame lengthwise. The colored side of the cover is the outer and the white side is the inner side of the Cover.

The line of embedded grommets on the inside (white) of the cover on the tie down flap runs parallel to the sides of the unit. Remember to keep the colored side of the fabric on the outside.

Once cover is properly oriented to frame, pull MAIN COVER over the top of the frame, being careful not to snag the cover on any frame member, bolts or other obstruction. Center the cover over the frame.



Pull Main Cover over frame with rope threaded through one of the grommets near the end flap. Be careful not to snag or rip the cover on any exposed bolts or rough ends.

The end of the Main Cover goes OVER the outer edge of the Door Panels on both ends. Adjust the cover on the frame so there is an equal amount of fabric on both ends.

STEP 3. TIGHTEN COVER DOWN LENGTHWISE

The Main Cover will tighten down in a similar manner as the End Panel/Doors. Take the remaining turnbuckles, fully loosened and place into the holes in the Corner leg Feet, FROM THE OUTSIDE. Tie off one end of the rope to the turnbuckle, take up extra slack, tie off that end temporarily to hold its position. Go to opposite end of unit, do the same. Adjust gathers in material evenly around arch. Keep repeating until Main Cover is snug and gathers are evenly distributed. It is important to work evenly from end to end, this will keep the cover from

pulling to one side more than the other. Cover can be tightened further by adjusting the turnbuckles.



Turnbuckle on Main Cover goes on the Outside of the End Panel/Zipper Door

STEP 3. LACE MAIN COVER TO FRAME

Once cover is completely aligned and secure, you will lace each side of the cover to the BOTTOM CROSS RAIL.. Start at one end and tie off the ROPE to the CROSS RAIL. Lace the rope through the grommets in the cover flap, and back under the Cross Rail. Repeat down entire length of unit and tie rope end off at Base Cross Rail. Do the same for the other side.



STEP 4. RECHECK COVER & DOORS

Retighten or readjust Main Cover and Doors if needed by adjusting the turnbuckles. Retighten the laced rope.

Pay close attention to how tight the cover is put onto the frame. It should be tight enough so it does not flap around in the wind, but not so tight that it tears the

material cover. The fabric backed PE fabric of MDM Products units does not stretch. If you pull it so tight that the fabric is stretched, a small amount of additional stress from wind or contact can cause premature tears and failure. Only tighten cover enough to remove valleys between arch assemblies. Do Not over tighten.



Inside Corner view showing Main Cover and End Panel Door properly laced and secured with turnbuckles.

BOTH THE COVER AND END PANELS SHOULD BE CHECKED AND TIGHTENED ON A MONTHLY BASIS.

You can now install the Door Roll-up Kit that was provided with your unit. Your kit is meant for ONE end, two doors. You can purchase an additional kit for the other end if desired from our Customer Service Department 1-800-447-7079 or our website www.mdmproducts.com



COMPLETED STRUCTURE

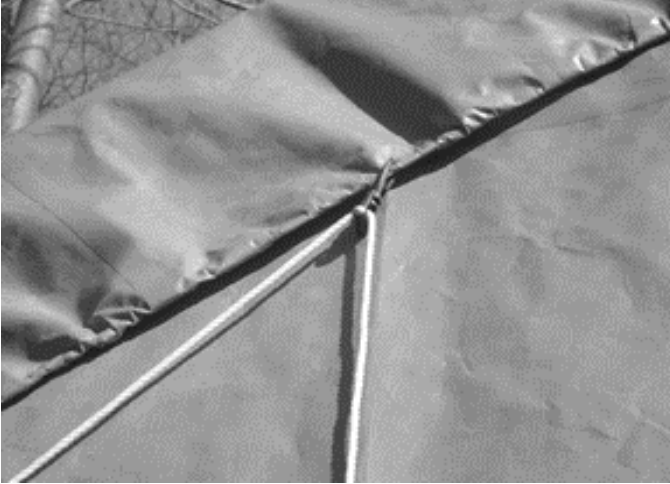

The roll up door kit rollers should be positioned along the width of the door equal from both ends.

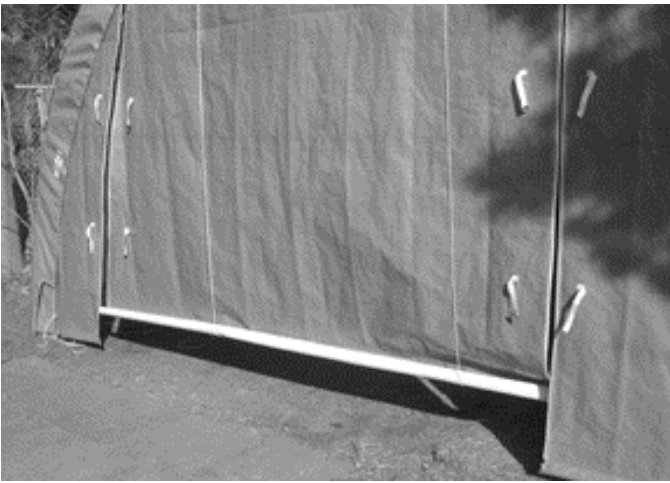

Place the two-piece rail into the base pocket of the doors for weight and rigidity to roll easily.





Maintenance and Care

Annually or more often, the unit should be completely inspected internally and externally to make certain the unit remains properly installed and secured. Particular attention should be paid to:

Hardware – check all carriage bolts and hardware connectors to be certain they are in place and tightened.

Anchors – during normal weather trends, the unit will strain against the anchors under windy conditions. Anchor hardware connection to frame members should be maintained tight and depth of anchors should be checked to be certain they remain deeply and firmly set.

Snow Accumulation – All snow accumulation on the main cover should be removed as soon as possible. Tap the main cover from the inside with a broom or soft brush to clear cover. Unit is not designed for any amount of accumulated snow or ice. Warrantee does NOT cover damage due to snow accumulation.

Main Cover Lacing – the poly rope that secures the main cover to the bottom rail of the frame assembly should be checked, and adjusted as needed. The tension on the main cover should be uniform from end to end and side to side. Rope ends must be tied off onto the frame members at the ends on each side.

Turnbuckle Adjustment – during normal wind conditions and load, the doors and main cover adjustment points at the turnbuckle should be checked and tightened as necessary. The turnbuckles should be neither completely extended nor taken up, so that turnbuckle should be tight when in the mid range of overall adjustment. If necessary, readjust rope tie off on turnbuckle as needed to tighten or loosen as needed.

Cleaning – cover and doors can be cleaned with a mixture of light detergent and water. A soft bristle brush with the mixture can be used to loosen any hard dirt, mold, or buildup on the cover. After cleansing, the cover should be rinsed thoroughly to avoid any chemical reaction from residual detergent. Allowing dirt and debris to sit on cover over an extended time will damage cover irreparably.

Severe Weather – in preparation for inclement weather, completely secure the doors on both ends of your MDM Products portable building. Allowing wind to enter either end lifts the building and puts undue stress on the

anchoring system. This also shortens the life of the doors, zippers, and main cover.

Door Operation – **Every time** doors are put down the zipper must be pulled down completely, and the snap buckles **MUST** be put together and adjusted. Failure to do so will cause door zipper to fail prematurely. Door area is so large that wind can pull zipper apart if the snap buckles are not adjusted to take the stress of wind.

Customer Service or Installation Assistance

Please call MDM Products at 800-447-7079 or 203-877-7070 for questions about the proper installation of the unit in any way. Care and attention to a proper installation will add many years of life and function to your MDM Products unit.

Please retain purchase documentation for your MDM Products unit. All warranty claims must include purchase documentation for verification. All parts on your MDM Products unit are available for replacement as needed. Protect your purchase by completing warranty registration card and mail/fax as soon as practical after installing your unit.

Thanks again for choosing this quality product. With proper operation and care we are confident it will meet your expectations in functionality, appearance and longevity.

INVENTORY CHART

| Item Number | Part Number | Description | Qty |
|--------------------|--------------------|---|------------|
| 1 | CT-7006 | Crest Tube – Swedged End | 21 |
| 2 | CT-7007 | Crest Tube – Fem X Fem | 7 |
| 3 | CT-7008 | Arch Side Tube | 14 |
| 4 | EUL-7002 | Arch End Upright w/Foot | 6 |
| 5 | EUL-7003 | Arch End - Plain | 8 |
| 6 | CW-7005 | Corner Wind Brace | 4 |
| 7 | ECR-7003 | End Cross Rails – Plain Ends | 7 |
| 8 | SCR-7004 | Cross Rail Pieces – swedged one end | 35 |
| 9 | EP-1001 | End Plug 1” | 14 |
| 10 | EP-1003 | End Plug 2-3/8” | 6 |
| 11 | CBN-7005-4 | Carriage Bolt – 3/8”X 4” | 49 |
| 12 | CBN-7005-CW | Curve Washer – 3/8” | 55 |
| 13 | CBN-7005-3 | Carriage Bolt – 3/8”X 2-7/8” | 14 |
| 14 | CBN-7005-W | Flat Washer- 3/8” | 8 |
| 15 | CBN-7005-N | Locknut 3/8” | 63 |
| 16 | TB-3004 | Galvanized Turnbuckles | 8 |
| 17 | R-7003 | 3/16” Rope | 2 |
| 18 | DBA-3000 | Duckbill Cable Anchors | 14 |
| 19 | UB-3002 | U Bolt w/ Nuts | 14 |
| 20 | DR-3001 | 36” Steel Drive Rod | 1 |
| 21 | ** | Door Bottom Pipe 1” X 72” Plain End | 2 |
| 22 | ** | Door Bottom Pipe 1” X 72” Swedged One End | 2 |
| 23 | ** | Roller Pulley | 4 |
| 24 | ** | Rope for Door ¼” X 49’ | 2 |
| 25 | ** | Bolt ¼”X 1-3/8” | 2 |
| 26 | ** | Self Tapping Screw ¼”X ½” | 2 |
| 27 | ** | Tie Off Rope Cleat | 2 |
| 28 | MUC-7000 | Main Cover | 1 |
| 29 | TZD-7002 | End Panel Door – Triple Zipper | 2 |
| | | | |

** - Parts included in Roll Up Door Kit