

MF 2201



5/05

Specification Sheet

MF2201

Size: 74" x 28 1/2" x 38 1/2"
Weight: 240 lbs.
Features: Arched back
Seat: 1/4" x 1 1/2" hot rolled steel
Arms/Legs: 5/8" x 2" hot rolled steel
Anchoring: Optional per request.

Color Selection:

Black - Green - Yellow
Beige - Brown - Red
Burgundy - Blue

Custom colors are available upon request

Metal Form Flat Steel Specifications

Finish Specification

Metal Armor Coating Performance Properties

Thermoplastic functional polyethylene copolymer-based coating

Coverage: 20mils minimum

Flexibility: 1/8", no cracks

Adhesion: >1000 psi/(5A)

Impact Resistance: >384 in/lbs

Gloss: At 60 degrees – 35-60

Delta Shift: 1.77

Hardness: Shore D-48

Taber Abrasion: 90 mg loss - CS10 wheel
100 mg loss – CS17 wheel

Salt Spray Resistance: >4000 hrs

Humidity Resistance: No blistering or loss of
Gloss after 1000 hrs

Smoke Development: 10 Flame spread index
10 Smoke developed index

Chip Resistance: 8A

ASTM D 533

ASTM D 4541/ASTM D 3359

Scored and unscored/no peeling or removal

ASTM D 2794

ASTM D 523

1400 MJUV = 5 yrs (color tested: Red)

ASTM 2240

ASTM D 4060

ASTM B 117

ASTM D 2247

ASTM E 84

ASTM D 3170

Environmental

VOC Content: 0, 100% solids

Special Approvals

FDA approved for direct food contact and has USDA compliance for use within the product zone applications.

Health

NFPA Classification:

Flammability: 1

Health: 0

Reactivity: 0

WAUSAU TILE

P.O. Box 1520
Wausau, WI 54402-1520
Ph: 800-446-8020
Fax: 715-355-4627
www.wausautile.com

SPECIFICATIONS

MF 2201 Bench

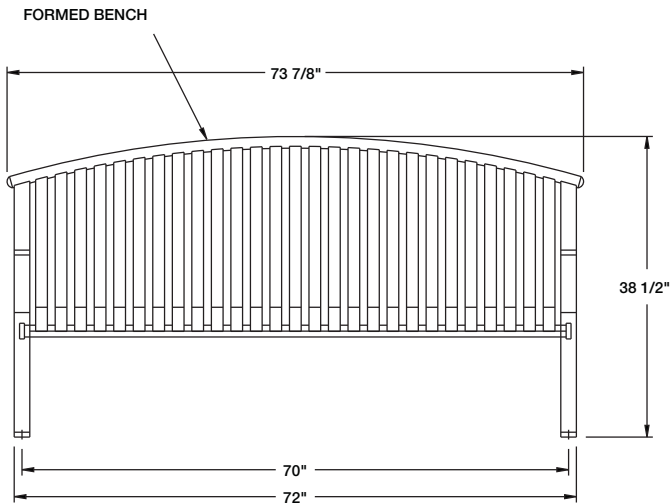
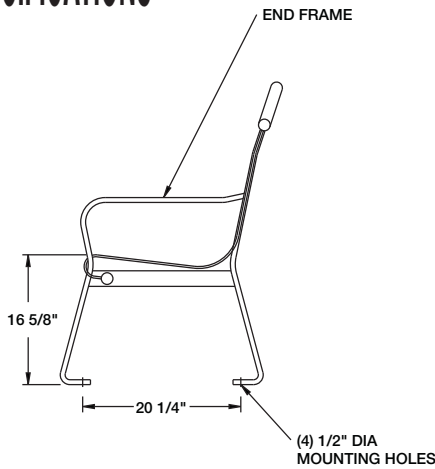

ANCHOR DETAIL

To install Rawl-Bolt™ one piece heavy duty anchors, follow simple instructions below:

1. With fixtures in place, drill hole of same nominal diameter as the Rawl-Bolt.™
2. Remove tag from assembled anchor. Insert anchor through hole in fixture.
3. Tap Rawl-Bolt™ into hole until washer and bolt head are seated against fixture.
4. Tighten with wrench.

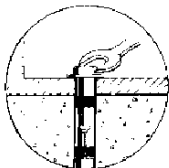
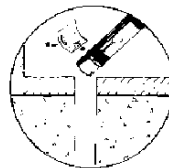
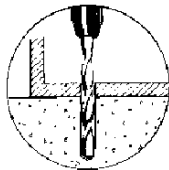

1.1 SUMMARY

- A. Section includes: Furnish Metal-Form benches on drawings or specified herein.

1.2 REFERENCES

- A. American Society for Testing & Materials
 1. ASTM-D533 ASTM-D4541 ASTM-D3359 ASTM-2794
 - ASTM-D523 ASTM-4060 ASTM-B117 ASTM-D2247
 - ASTM-E84 ASTM-D3170 ASTM-A569 ASTM-B6
 - ASTM G26 ASTM-A569/A569M

1.3 SUBMITTALS

- A. Submit product data, shop drawings and samples.
 1. Product Data: Manufacturer's specifications and technical data edited specifically for proposed product, including the following specific information:
 - a. Detailed specification of construction fabrication.
 - b. Manufacturer's installation instructions
 - c. Product warranty
- B. Shop Drawings: Indicate pertinent dimensions, general construction, component connections, anchoring methods, hardware and installation procedures.
- C. Samples as requested by Architect.

1.4 QUALITY ASSURANCE

- A. Qualifications of Manufacturer: Manufacturer to be prequalified by specifier prior to bidding. Failure to comply will result in disqualification of bid. Manufacturer to have at least three years experience in the manufacture of thermo plastic coated steel site furnishings field proven for at least three years.
- B. Warranty: 5 Years - Metal Armor Coated Products

1.5 MANUFACTURERS

- A. Acceptable manufacturer for thermo plastic coated steel site furnishings to be known as:
 Wausau Tile, Inc. Metal-Form Division
 PO Box 1520
 Wausau, WI 54402-1520
 (800) 446-8020 FAX (715) 355-4627
- B. Clarification Note: Drawings and installation specifications are based on manufacturers proprietary literature from Wausau Tile, Inc., Metal-Form Division. Other manufacturers shall comply with minimum levels of material and detailing indicated on drawings or specified herein.