



INTRODUCTION

This anchor kit is intended for use on all Arrow storage buildings.

TOOLS AND MATERIALS REQUIRED

- Carpenter's Level
- Drill (Electric)
- Safety Glasses
- 1/8" Drill Bit
- 1/4" Drill Bit
- Work gloves & long sleeves
- 1/4" Masonry Drill Bit (Supplied)
- #2 Phillips Head Screwdriver
- Tape Measure
- 3/8" Wrench
- Hammer

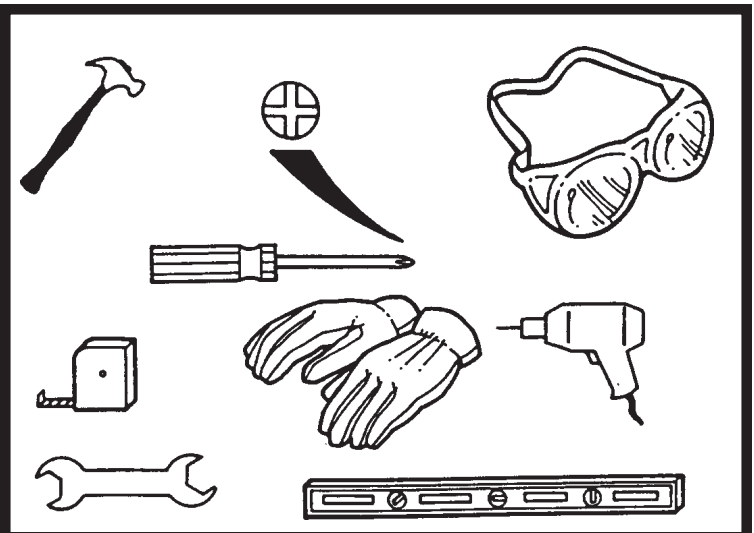

ASSEMBLY INSTRUCTIONS:

Read the instructions and study the illustrations carefully. Follow the step by step instructions to properly Anchor your Storage Building.

RETAIN THIS MANUAL AND PARTS LIST AFTER ASSEMBLY FOR FUTURE REFERENCE.

CHECK THE CONTENTS:

Check the contents of carton against the Parts List. Identify parts to those shown in the illustrations. This will help you become familiar with the parts on sight.

SAFETY RULES:

- Make sure no one is in path while drilling.
- Wear safety glasses, work gloves and long sleeves while drilling.

ANCHORING THE STORAGE BUILDING TO A CONCRETE PATIO OR SLAB

This concrete Anchor Kit comes complete with masonry drill bit, fasteners and easy to follow instructions. For proper installation, it is important that the overall size of the patio/slab have approximately 9/16" clearance between frame and edge of concrete around entire perimeter.

IMPORTANT: Make sure Floor Frame is level and square before proceeding with the anchoring.

One (1) Anchor Kit is recommended for most buildings. Anchors are used at each corner and spaced evenly along the Floor Frame.

NOTE: The following must be considered before starting to drill concrete for installation of Hold Down Clips:

1. If your building has Floor Frame Splices.
 - A. Assemble and position Floor Frame.
 - B. Mark and drill hole location as described above.

This kit contains four (4) Gussets to anchor the Floor Frame corners. If your building is supplied with Gussets (some models have them), disregard the ones supplied with the building.

PARTS LIST ANCHOR KIT #AK100

| Key # | Part # | Description (Quan.) |
|-------|-----------|---------------------------------|
| 1 | 8397 | Corner Gusset (4) |
| 2 | 8398 | Hold Down Clip (11) |
| 3 | 66159 | Anchor Bolt (16) |
| | | #10 x 1/2" Screw (39) |
| | | Masonry Drill Bit-1/4" Pack (1) |
| - | 704960196 | Instruction Folder (1) |

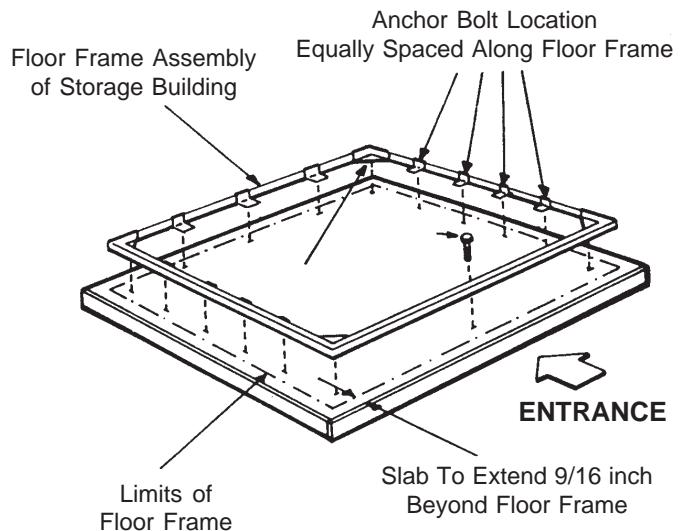
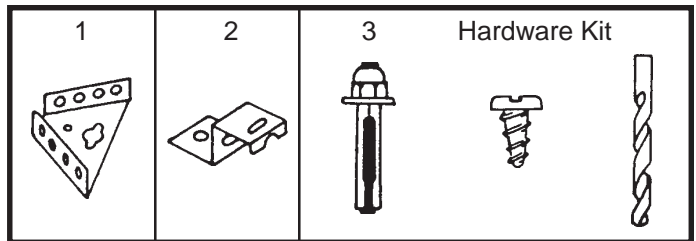

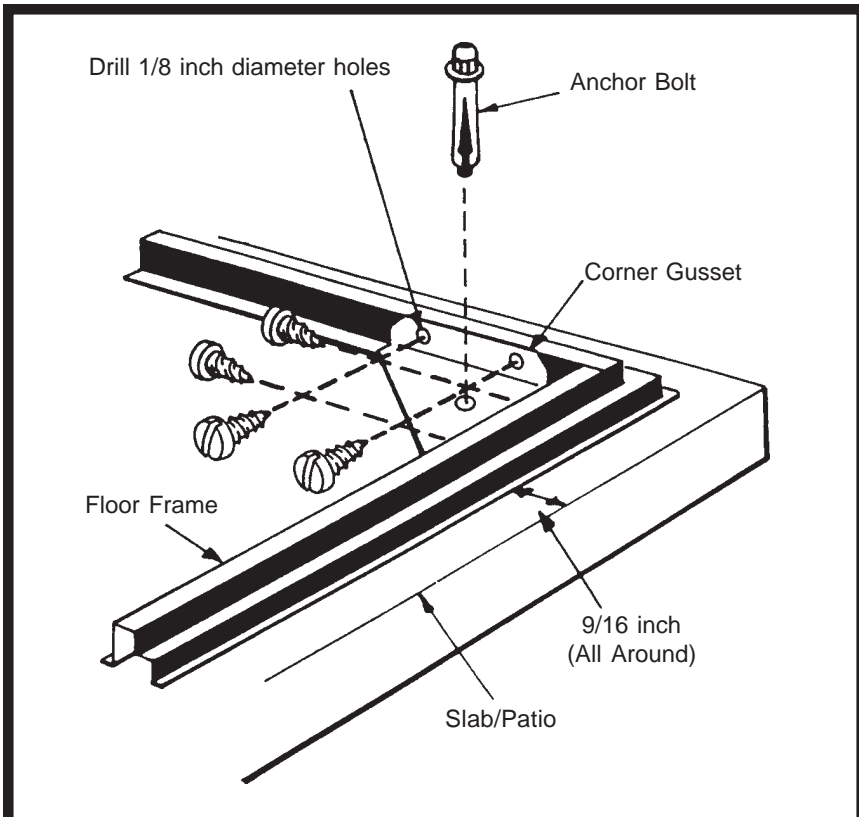

STEP 1

Corner Gusset Installation

1. Position Gussets into corners of Floor Frame with flanged edges "UP".
2. Attach Gussets through aligning holes, or drill 1/8" holes.
3. Through hole in center of Gusset, drill 1/4" diameter hole in concrete using the Masonry Drill Bit supplied. **IMPORTANT:** Holes drilled in concrete must be at right angle to surface and 2" deep. Use drill bit furnished. Holes must not be more than 1/32" over size or anchor bolts will not hold.
4. Place **Anchoring Bolt** in hole drilled and tap head with hammer to set into place. Tighten nut with wrench.

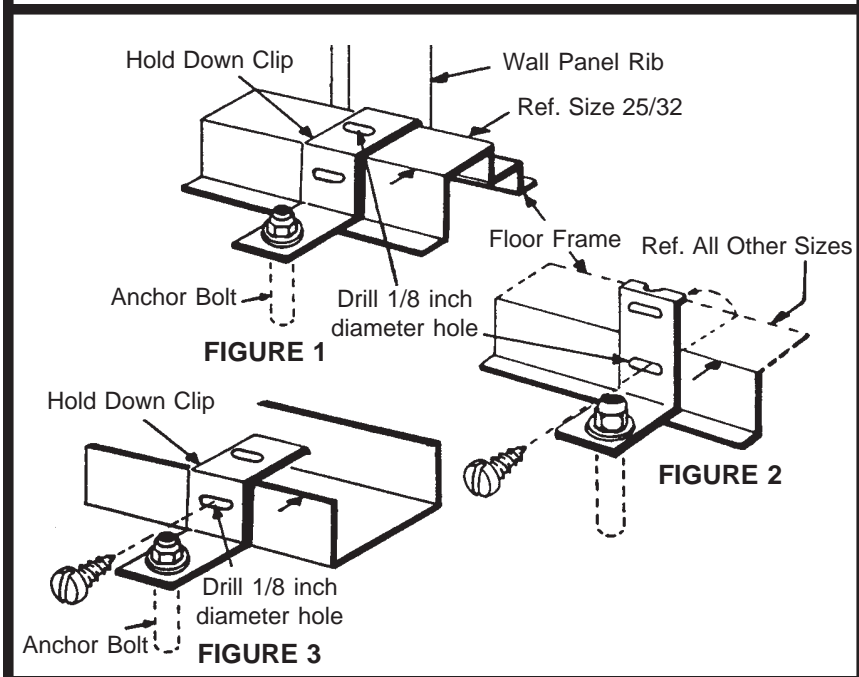

STEP 2

Hold Down Clip Installation

1. Position Clips on Floor Frame (by panel rib) at equally spaced intervals and attach using screws through existing holes or drill 1/8" holes. See Figure 1, 2 or 3.
2. **NOTE:** If other size Floor Frames (Figure 2) are to be anchored, you must bend Hold Down Clips "UP" before attaching to Floor Frame. (Figure 3) is for buildings 12'x10' through 14'x31' with channel style floor frames. Additional kits may be required.
3. Drill holes in concrete and anchor Clips to concrete in same manner as described in Step 1.

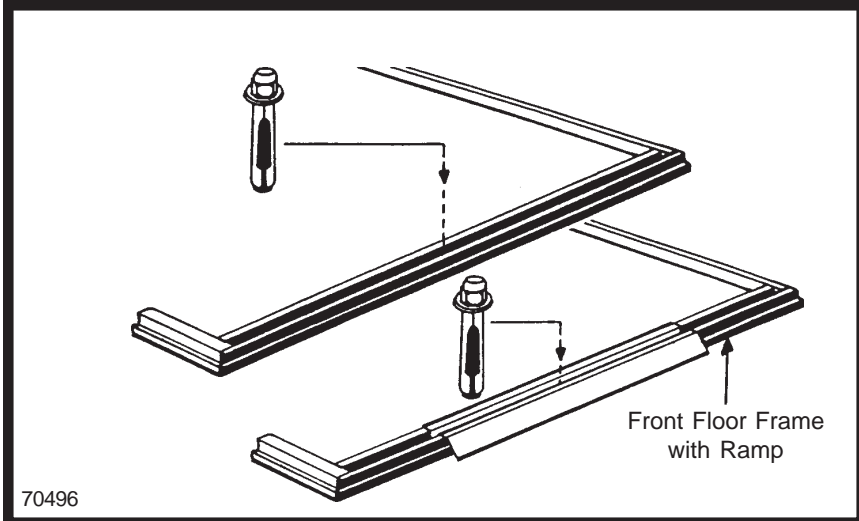

STEP 3

Front Frame Anchor Installation

1. Drill 1/4" hole at center of Front Floor Frame as shown. Switch to Masonry Bit supplied and continue drilling to a 2" depth.
2. Anchor Frame to concrete with an Anchoring Bolt in the same manner as described in Step 1.

For replacement parts or any questions concerning your anchor kit, include the model no. of your kit and contact:

Arrow Group Industries, Inc.
Customer Service Department
Route 50 East
Breese, Illinois 62230
1-800-851-1085