

Gazebo Shelf/Bench 10', 12' and 14' Models

#16689

-BEFORE YOU BEGIN-

■ First...

Read these instructions thoroughly before you begin assembly. Assembly is easiest if you follow the steps in the order shown.

■ Check all parts

Compare the parts you have to the list, If a part is missing, circle the part in question and call our toll-free # at (800) 437-0784.

■ Staining...

This Shelf/Bench is constructed of a long-lasting western cedar. Untreated cedar exposed to sunlight will eventually weather to a silver-grey color. Applying Stain or Sealers per manufacturers instructions WITHIN 30 DAYS will improve the water resistance of your Shelf/Bench. Some sanding to remove rough edges and natural wood stains may be required prior to staining.

■ Tools Required

- Phillips Screwdriver
- Level
- Pencil

■ Optional Tools

- Electric Drill with #2 phillips Tip
- Drill Bit for Pre-drilling

PARTS LIST			
Part	Qty.	Description	Size
2	Vertical Bench Support		2x3x14-1/2"
2	Horizontal Bench Support(notched)		2x3x14-1/2"
2	Shelf Support		2x3x10"
2	Corbel		2x4x14"@45°
1	Shelf/Bench Assembly		

- Hardware
 - (24) #10 3-1/2" Screws
 - (6) #8 2-1/4" Screws

Always wear OSHA-APPROVED safety glasses throughout the assembly process

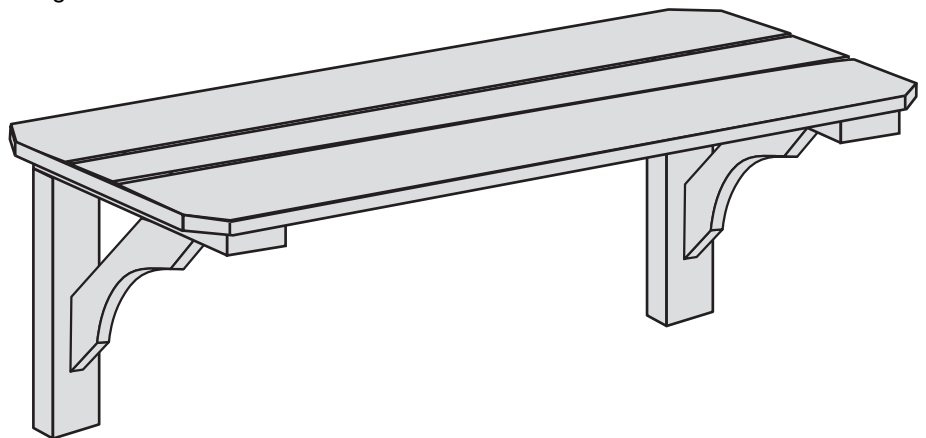

1-A: If installing a Bench, see **Fig.1**.

If installing a Shelf, see **Fig. 2**.

Attach Horizontal Support to Vertical Support with 3-1/2" screws through pre-drilled holes. Attach Corbel to Horizontal and Vertical Support with 3-1/2" screws through pre-drilled holes. Make two assemblies.

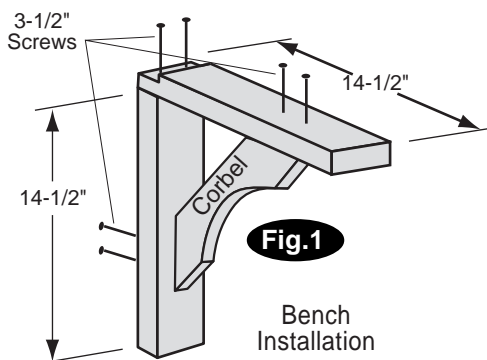

1-A

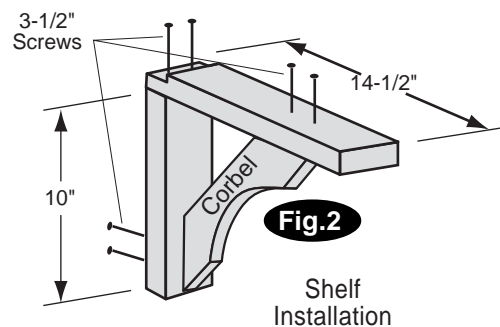

1-B: Bench Assembly

Place assembled bracket tight against floor in corner of Gazebo with wall supports angling towards the middle. Fasten with (6) 3-1/2" screws through pre-drilled holes into wall. Attach the other bracket in the same manner. Continue with step 1-D.

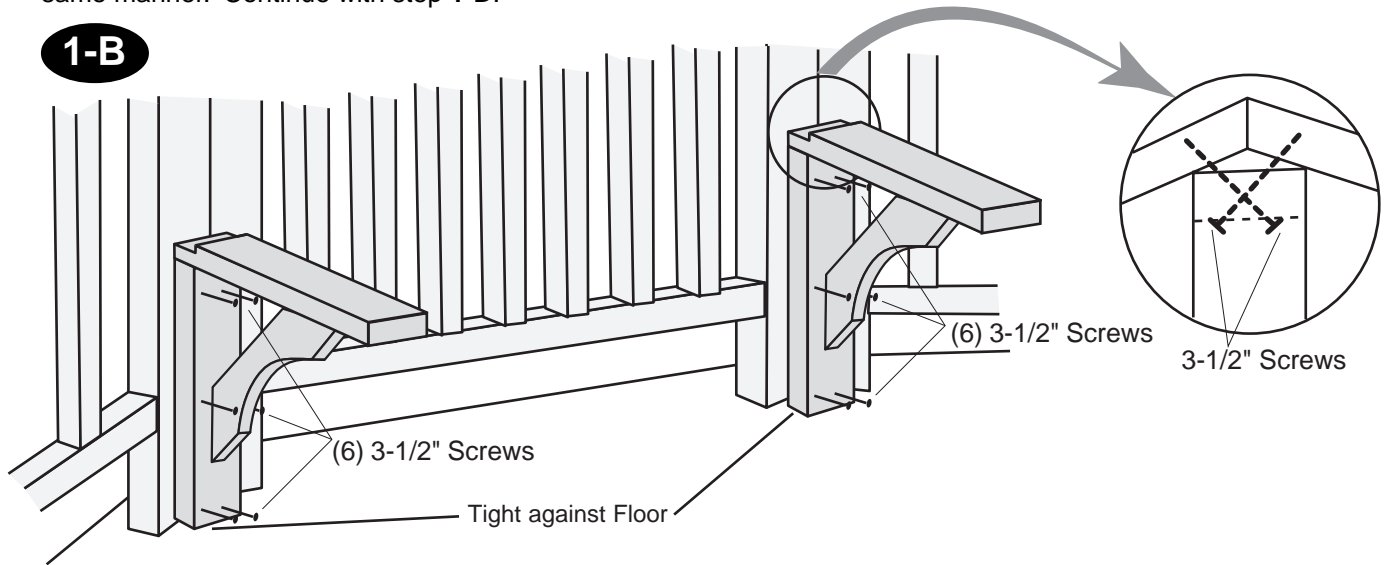

1-C: Shelf Assembly

Place top of assembled bracket 1" below top of Sill Plate in corner with wall supports angling towards the middle. Fasten with (4) 3-1/2" screws through pre-drilled holes into wall. Attach the other bracket in the same manner. Continue with step 1-D.

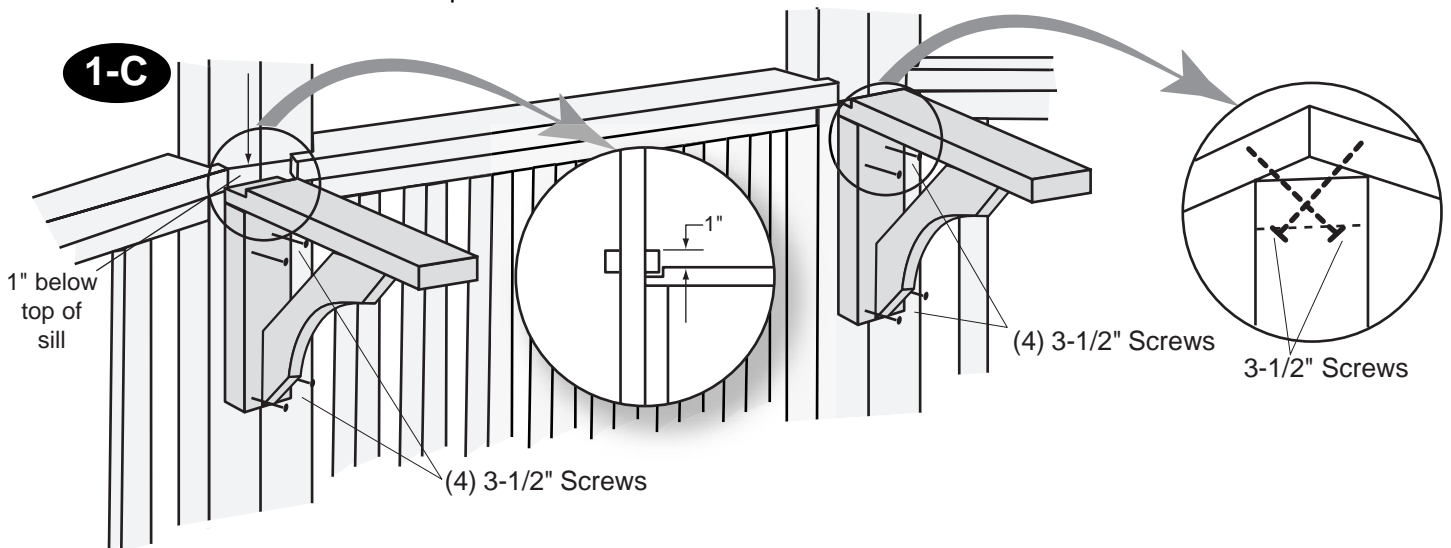

1-D

1-D: Place assembled Bench/Shelf top on the brackets attached to the wall. Center and attach with (6) 2-1/4" screws from underneath. Keep 1/4" gap between Sill and Shelf.

Note: The max load on the shelf is 30 lbs. For heavier loads on the bench, drill through wall and bench bracket and attach 4" bolt and washers for extra strength.

