



BRIGHTON[™]
BY LIFETIME

11' x 11'
OUTDOOR SHED



Owner's Manual with Assembly Instructions

Brighton 11' x 11' Outdoor Shed MODEL #6433

You could win \$200!

Register your product at www.lifetime.com and receive three important benefits:

1. You automatically will be entered to win \$200 in our monthly drawing!
2. In the unlikely event of a product recall or safety modification, we can notify you immediately and directly.
3. You may choose to receive Preferred Customer Announcements and promotions regarding new Lifetime products.

www.lifetime.com

Level Surface Notice:

Surface must be leveled before installation. We recommend building a level work space with a cement or patio style surface. If the surface is not properly leveled, the Outdoor shed will not assemble correctly. Proper surface leveling will save you time in the long run, so please do not ignore this step.

Building Code Notice:

Consult all local building codes, as well as city and county ordinances, to ensure that the construction of the Outdoor Shed does not require a building permit. Proper building permit documentation may be required in your neighborhood, and it would be unfortunate to learn this after constructing the Shed.

Screwdriver Notice:

You may use a 1/2" phillips head screwdriver bit and a power screwdriver or drill, instead of a hand screwdriver. However, be aware that the plastic pieces of your shed can be damaged by overtightening of screws. To avoid damage we strongly recommend the use of a low-powered power screwdriver or a drill that has an adjustable clutch that is set on a low torque setting. If neither is available, use a hand screwdriver. In any case use caution to avoid overtightening the screws.

Floor Puncture Notice:

Sharp objects may damage your floor. If resting sharp, heavy objects on your shed floor, place a block of wood between the sharp object and floor.



SAFETY INSTRUCTIONS



**FAILURE TO FOLLOW THESE WARNINGS MAY RESULT IN SERIOUS
INJURY OR PROPERTY DAMAGE AND WILL VOID WARRANTY.**

To ensure safety, do not attempt to assemble this shed without following the instructions carefully. Check entire box and inside all packing material for parts and/or additional instruction material. Before beginning assembly, read the instructions and identify parts using the hardware identifier and parts list in this document. Proper and complete assembly, use and supervision are essential for proper orientation and to reduce the risk of accident or injury.

- Do not use or store hot objects such as grills, blowtorches, welding equipment, etc. in the shed.
- If using a ladder during assembly, use extreme caution.
- Two capable adults are required for shed assembly. (It is also recommended that a third adult function as an instruction reader.)

Most injuries are caused by misuse and/or not following instructions. Use caution when using this shed.



Read This First!



Before Beginning Assembly:

- A. Read the "Congratulations" letter on pages 4-5.
- B. Remove Parts List from the center of these instructions and make sure all parts are present and in good condition.

****Do Not Contact the Store!****
For Assistance, including missing or broken parts,
Call Customer Service at:
1 (800) 225-3865

**** Customers outside of the U.S. or Canada, please contact the store for assistance. ****



Indicates a helpful hint or important note.



Indicates that a hand screwdriver is required for a step.

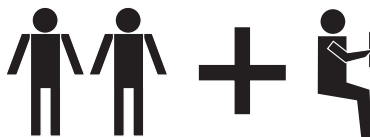

Two Adults Required for Assembly
 (+ one Adult suggested as an instruction reader)

Suggested Tools & Materials (Not Included):					
7/16"	3/8"	Adjustable	Rubber Mallet	Box Knife	Phillips Head
(2)	(1)	(1)	(1)	(1)	(1)
Step Ladder	Power Drill *	Work Light	Pliers	Flashlight	
(2)	(1)	(1)	(1)	(1)	

* see "Screwdriver Notice" on page 2

IMPORTANT! Please Read

Dear Valued Customer,

We would like to congratulate you on your purchase of a Brighton™ Outdoor Storage Shed! We are confident that you have made the perfect choice and you will be very pleased with your new storage solution.

Brighton™ Outdoor Storage is part of the family of brands created and manufactured by Lifetime® Products, Inc. Like all of our products, you can be assured that the quality of your Lifetime Outdoor Storage Shed is the best in the world! All of our sheds are made in the USA, something that is very important to us. And, we back that quality up by offering the best warranty in the business – A 10-year warranty that fully covers the shed!

All of our sheds are built with the highest-quality steel and polyethylene parts. The design and construction of our steel-reinforced double-wall panels is second to none. All of our exposed steel parts and trusses are powder coated and we use high-impact polyethylene plastic. What makes polyethylene so special? It has superior strength and durability, and, it won't crack or degrade outdoors.

So now that you know the quality you are getting in a Lifetime Outdoor Storage Shed, please take the time to **READ THIS INSTRUCTION MANUAL!**

We have taken great care in providing the best possible form of instructions to help you put your new Outdoor Storage Shed together. Before you get started, **PLEASE** read the following preparation tips to help you get started!

We can assure you, your construction experience will be a lot more enjoyable if you do!

PREPARATION TIPS:

- The first step is simple...**RELAX!** You have made a great purchase, but Rome was not built in a day. Plan to spend a good part of your afternoon putting together your fine Outdoor Storage Shed. Our philosophy is, if it comes together quickly and easily, it surely will come apart quickly and easily! Your Lifetime Outdoor Storage Shed will surely last a long, long time, if you are patient, and take all the time necessary to put it together as we have instructed.
- Grab a friend to join in on the fun! This is not a one-person endeavor. We have found that not only will things go smoother if you have two or more people participating in the construction of the shed, but it will go quicker as well. So, the more the merrier!
- Make sure you have all the tools necessary for constructing your new shed. There is a "Suggested Tools & Materials" list on page three of this Owner's Manual.

- The plastic pieces of your shed may become damaged by over tightening the screws. To avoid this damage, we strongly recommend the use of a low-powered power screwdriver or a drill that has an adjustable clutch that is set on a low-torque setting. If neither is available, use a hand screwdriver. If a hand screwdriver is all you have, take several breaks...your wrist will need it!
- You will also need two small step ladders (when it comes time to do the roof!).
- Before beginning assembly, remove the Parts List from the center of this Owner's Manual and take an inventory of the parts included with your Outdoor Storage Shed. Also, read through the entire instruction manual. It's always a great practice to get a feel for the flow of the process and to familiarize yourself with the parts involved. But, try not to get ahead of yourself and start the process out of order.
- **FOLLOW THE INSTRUCTIONS IN ORDER!** Everything goes together in a certain order, and we have learned what that correct order should be. In our state-of-the-art research and testing facility, we have painstakingly created these instructions. The order of construction is there for a reason, and some parts simply will not fit if built out of order. Just follow along with the order in the instructions and everything will fit together and things will go very smooth.
- **YOUR SHED MUST BE BUILT ON A LEVEL SURFACE!** If the spot you have chosen to place your wonderful new Outdoor Storage Shed is not level, the shed will not assemble correctly! We recommend a cement patio, a wood platform or creating a pad with pea gravel. Your shed is meant to last a lifetime, so provide the proper foundation for it before you start to build.
- Before you build it, make sure you are allowed to build it! Consult all building codes, as well as city and county ordinances, to ensure that you do not require a building permit to construct your Outdoor Storage Shed. Proper building permit documentation may be required in your neighborhood, and it would be quite unfortunate to learn this after your Outdoor Storage Shed is already built!

Now that you're ready to begin the construction of your wonderful new Outdoor Storage Shed, step back, take a deep breath, get yourself a large cold beverage and enjoy yourself. We guarantee that after spending the right amount of time in building your shed, you will be able to enjoy it for years to come.

Thanks for choosing Brighton™ Outdoor Storage, and have fun!

1 Site Selection

1a The actual dimensions of your shed (at its widest and longest points) are 11' x 11.5'. Be sure to select a site that will accommodate these measurements. The base of the shed is slightly smaller than this, so you will need to create a level surface that is at least 124" x 124". We recommend using a level cement or patio style surface. This will provide the best long-term performance for your shed.

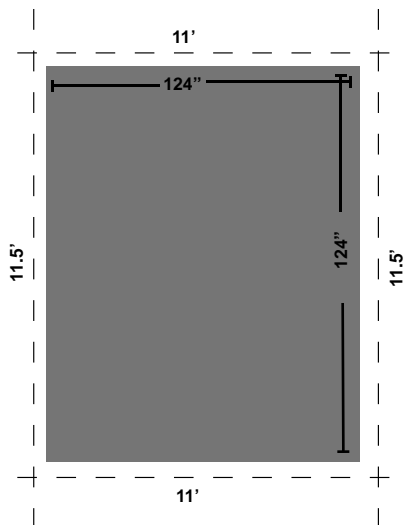

NOTICE: Shed Extension Kits are available for this shed. Please consider possible shed expansion when planning the site for your shed. See inside the back cover of this manual for information on ordering Extension Kits.



NOTE
Surface must be leveled before installation. If the surface is not properly leveled, the Outdoor shed will not assemble or function correctly. Proper surface leveling will save you time in the long run, so please do not ignore this step.

Alternate Site Preparation

Wherever possible you should use the surfaces described above. When this is not possible, we recommend you use one of the following options:

OPTION 1: Wood Platform

Be sure you use lumber that is treated and approved for outdoor use. Build outside frame to 124 inches by 124 inches outside dimensions:

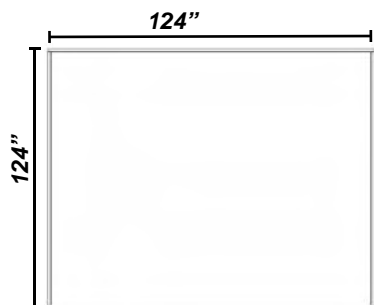

Item	Qty.
2" x 4" x 121" treated board*	9
2" x 4" x 124" treated board*	2
48" x 96" Plywood (ACX/Exterior)	2
28" x 96" Plywood (ACX/Exterior)	1
27" x 96" Plywood (ACX/Exterior)	1
27" x 28" Plywood (ACX/Exterior)	1
16d 3" common nails	36
8d 1 1/2" common nails	63

* All lumber must be rated for outdoor use

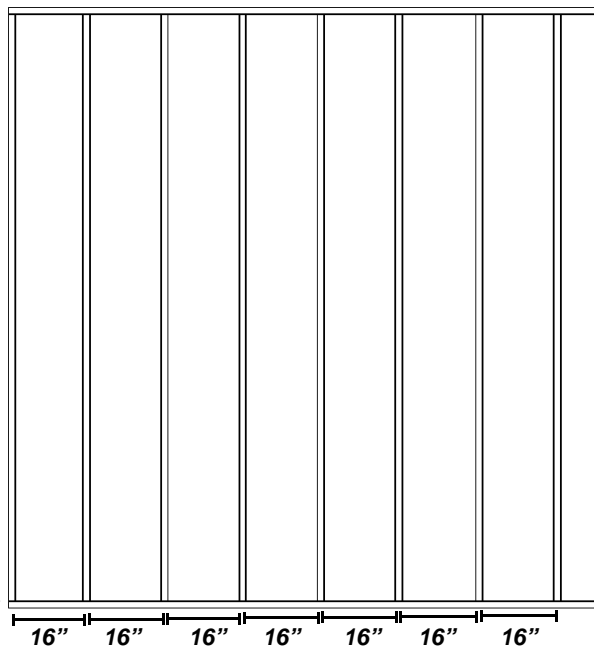

To be sure to have studs in the correct location to nail plywood in the next step, start measuring here & measure from center to center

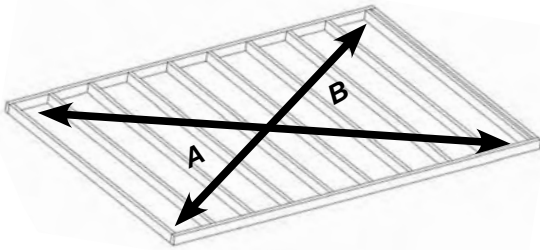

Square up the frame by measuring from corner to corner. Measurement A should equal Measurement B.

Cut Plywood into sizes called for on previous page. Arrange the Plywood according to the diagram and nail into place with 8d x 1 1/2" nails.

96" x 27"		28" x 27"
48" x 96"	48" x 96"	28" x 96"

Place platform in the desired location. If platform does not rest level on the ground, build up low points with loose dirt until platform is stable.

OPTION 2: Filled Wood Frame

Be sure you use lumber that is treated and approved for outdoor use. Cut outside frame to 124" by 124" outside dimensions:

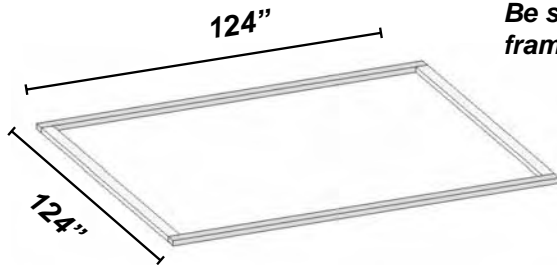

Be sure that frame is level.

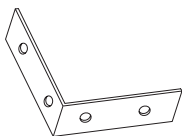

Nail an L-bracket on each corner of the frame with 8d nails.

Item	Qty.
2" x 4" x 124" treated board*	2
2" x 4" x 121" treated board*	2
8d 1 1/2" common nails	16
1" 'L' bracket	4
"Pea" gravel 13.4 cu. ft.	
Leveling board (2" x 4" x 14')	1

* Must be rated for outdoor use

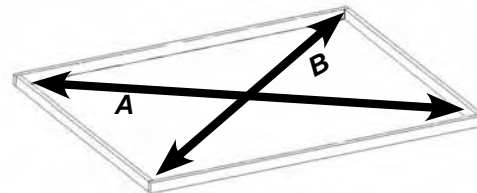

Square up the frame by measuring from corner to corner. Measurement A should equal Measurement B.

Place platform in the desired location. If platform does not rest level on the ground, build up low points with loose dirt or "Pea" gravel, until platform is stable.

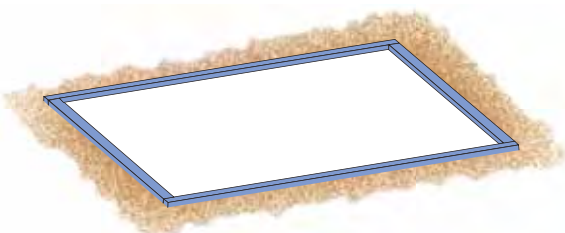

Once all boards are level and do not wobble, pack "Pea" gravel around the outside of the frame, and slope away from frame.

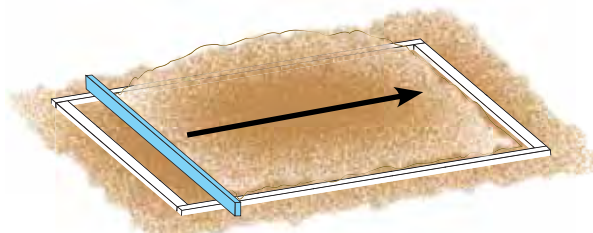

Now fill the inside of the frame with "Pea" gravel. Use a leveling board to scrape off extra fill material and to level the surface.

Before Beginning!

Remove the Parts List from the center of this manual, and organize Shed Parts.

2 Assemble Floor

- 2a Fit together an "A" and "B" Outer Floor Panel (AO & AP). Hold panels at an angle to fit panels together, then lay flat.

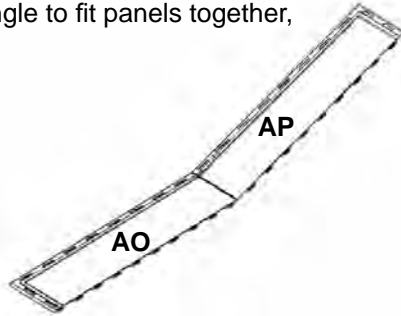

This Step uses:

2-Inner Floor "A" Panels (AO)
2-Inner Floor "B" Panels (AP)
6-Inner Floor Panels (JJ)

CAUTION

Sharp objects may damage your floor. If resting sharp, heavy objects on your shed floor, place a block of wood between the sharp object and floor.

- 2b Fit together two Inner Floor Panels (JJ) and connect to the Outer Floor Panels (AO & AP).

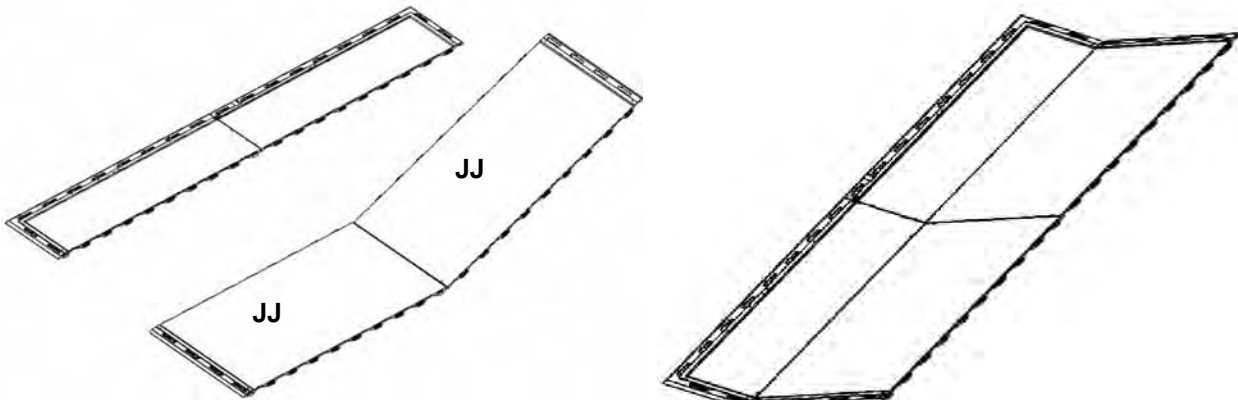

- 2c Repeat for remaining Inner Floor Panels (JJ).

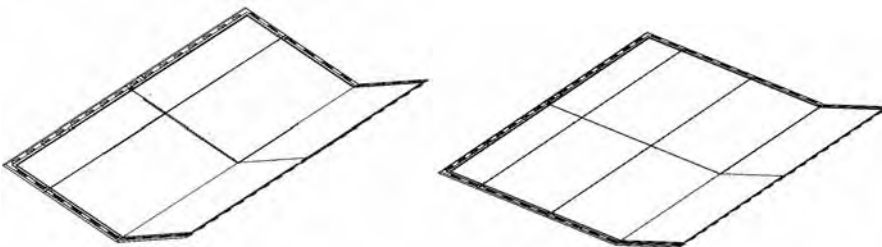

- 2d Connect the last two Outer Floor Panels (AO & AP).

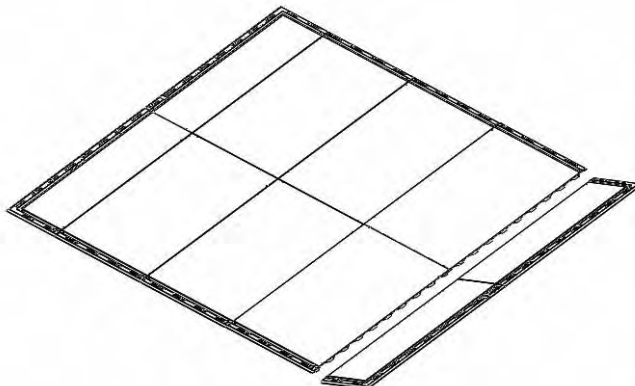

Assembly Tip #1

Inserting Wall Panels

1. Set Wall Panel Tabs into Floor Panel Slots.
2. Slide Wall Panel to the left until the Wall Panel locks into place.
3. Use a Rubber Mallet to nudge the panel into position. Be careful not to damage the edge of the wall panel.

3 Assemble Front Corner

3a Lock a Wall Panel (JF) into the front right corner position. Have one person hold this panel while a second person inserts the next wall panel.

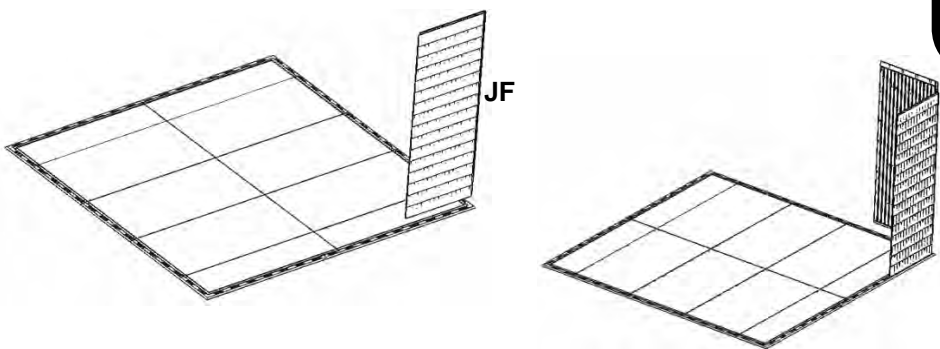

Step 3 Hardware

Hardware Bag: 1009126
Screwdriver

3b Secure both Wall Panels (JF) together with a Corner Channel (AI).

Assembly Tip #2

Installing Corner Channels

1. Loosely insert top two screws.
2. Insert bottom two screws (tighten completely).
3. Insert remaining screws (tighten).
4. Tighten top screws.

The top of the channel is the end with the holes closest to the end.

Assembly Tip #3

Window Locations

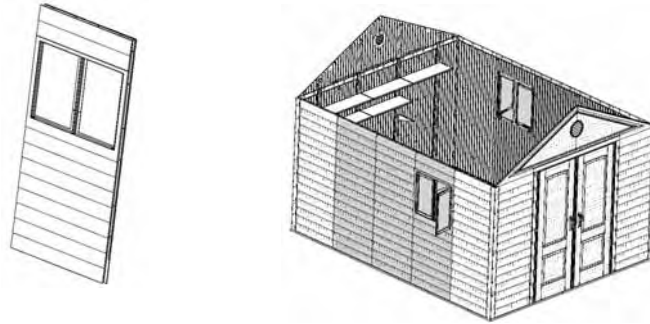

Window Wall Panels can be installed on either side (or the back) of the shed, in any of the highlighted locations (not in the corners).

Assembly Tip #4

Connecting Wall Panels

Note: Do Not over tighten screws, or the holes will strip.

1. Do not insert screws into any slot unless you can see the pilot hole behind the slot.

2. Align the tops of both wall panels and insert a screw into the top hole.

3. Push and hold bottoms of wall panels together. Insert bottom screw.

4. Work from the bottom to the top and install remaining screws. Completely tightened each screw.

①

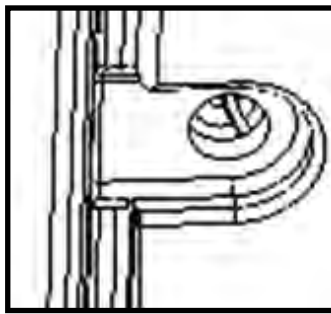

②

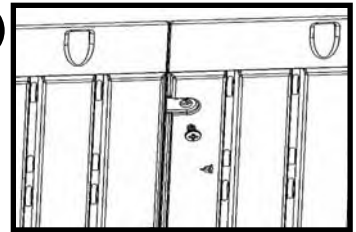

③

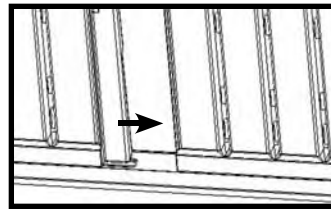

④

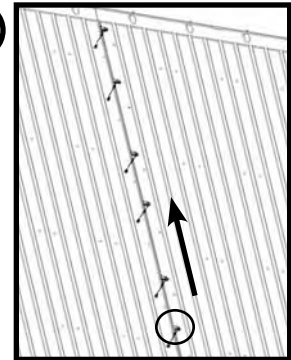

4

Assemble Side Wall

4a

Assemble the next two Wall Panels (JF). Secure the panels together with 1/4" Screws (FE) as shown. **See Assembly Tip #4 (this page).**

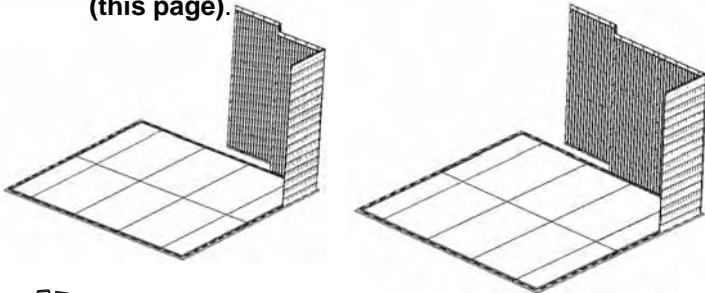

Step 4 Hardware

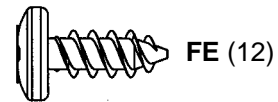

Hardware Bag: 1009126
Screwdriver



NOTE
Second person should apply pressure on opposite side of the wall for easy insertion of screws.

5

Assemble Next Corner

5a) Install next two Wall Panels (JF) at the back right corner of the shed. Then connect with a Corner Channel (AI). See Assembly Tip #2 (p. 9).

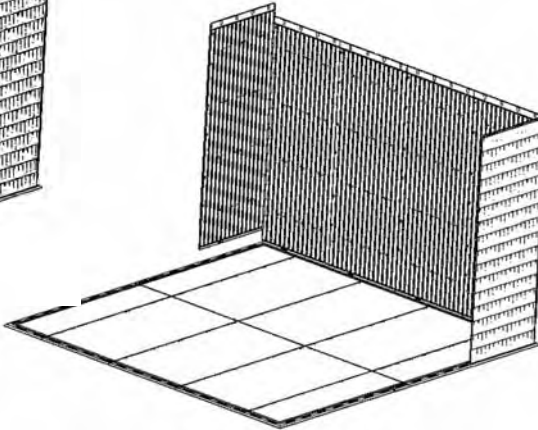
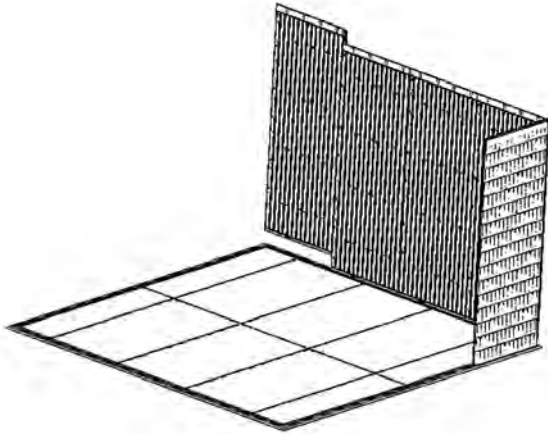

Step 5 Hardware

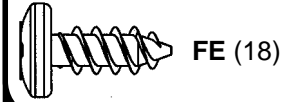

Hardware Bag: 1009126
Screwdriver

6

Assemble Back Wall

6a) Assemble next two Wall Panels (JF). Secure the panels together with 1/4" Screws (FE). See Assembly Tip #4 (p. 10).

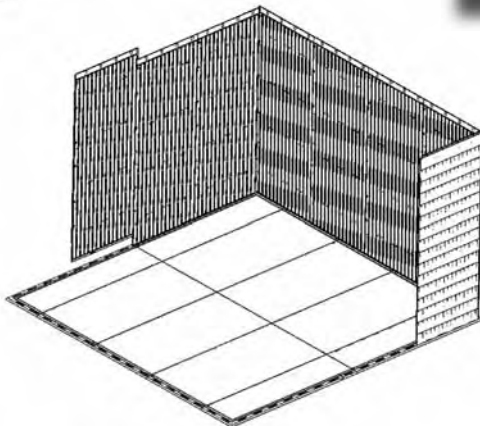
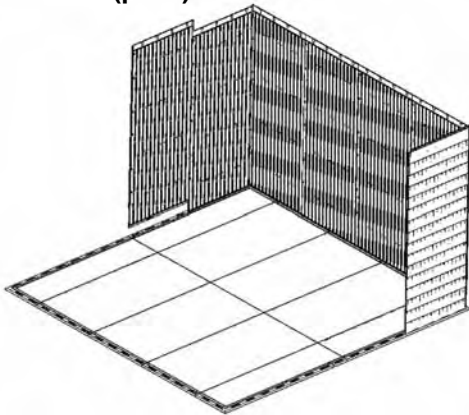

Step 6 Hardware

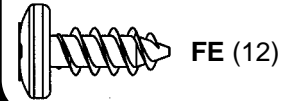

Hardware Bag: 1009126
Screwdriver



Second person should apply pressure on opposite side of the wall for easy insertion of screws.

7 Assemble Next Corner

- 7a Install Next two Wall Panels (JF) at the back left corner of the shed. Then connect with a Corner Channel (AI). **See Assembly Tip #2 (p. 9).**

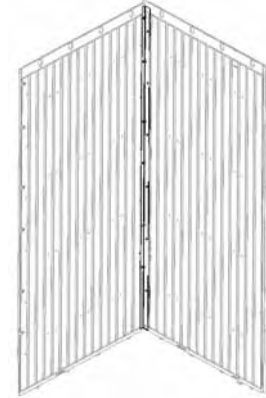
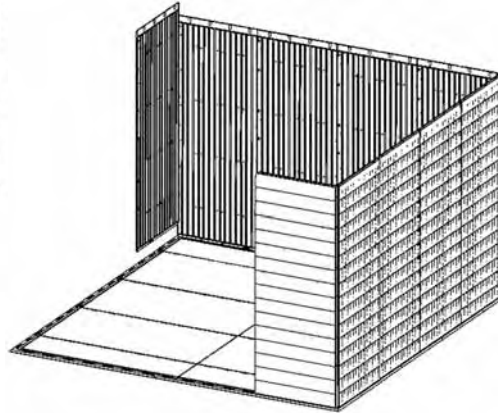
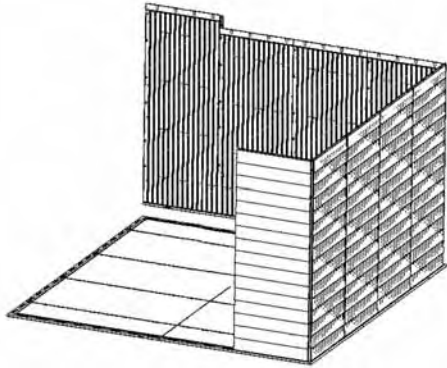

Step 7 Hardware

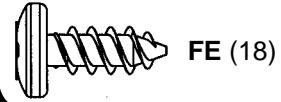

Hardware Bag: 1009126
Screwdriver

8 Assemble Left Wall

- 8a Assemble next two Wall Panels (JF). Secure the panels together with 1/4" Screws (FE) as shown. **See Assembly Tip #4 (p. 10).**

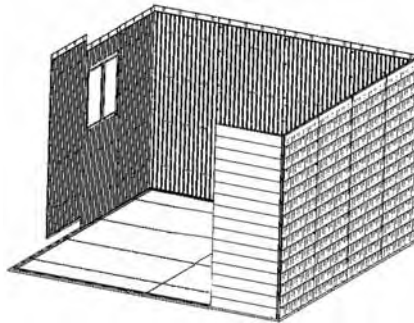
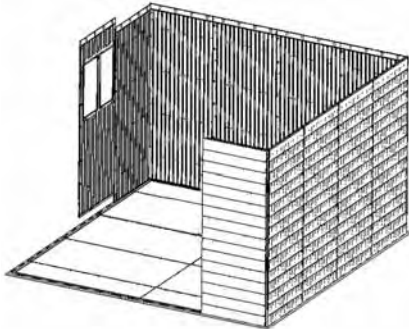

Step 8 Hardware

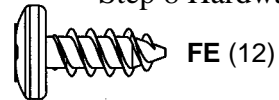

Hardware Bag: 1009126
Screwdriver



Second person should apply pressure on opposite side of the wall for easy insertion of screws.

9 Assemble Last Corner

- 9a Install Next two Wall Panels (JF) at the front left corner of the shed. Then connect with a Corner Channel (AI). **See Assembly Tip #2 (p. 9).**

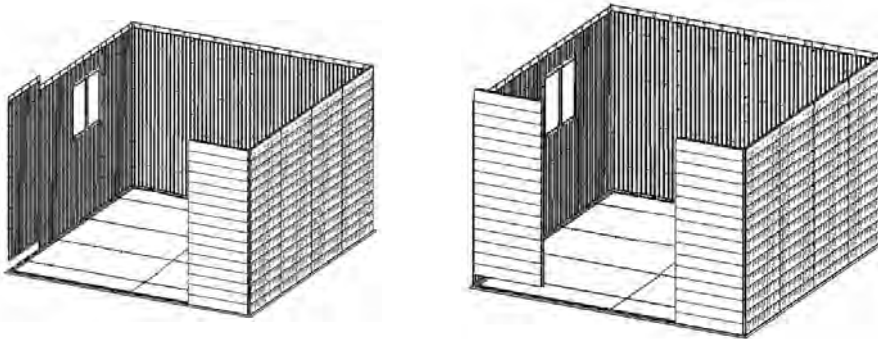

Step 9 Hardware

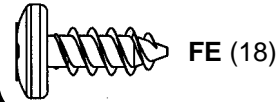

Hardware Bag: 1009126
Screwdriver



10 Install Trim to Corners

- 10a Snap six Black Trim Brackets (HA) to a corner of the shed. Fasten each Bracket with two #10 x 1/2" Screws (MM). There are no pilot holes in the shed wall, the screws are inserted directly into the plastic.

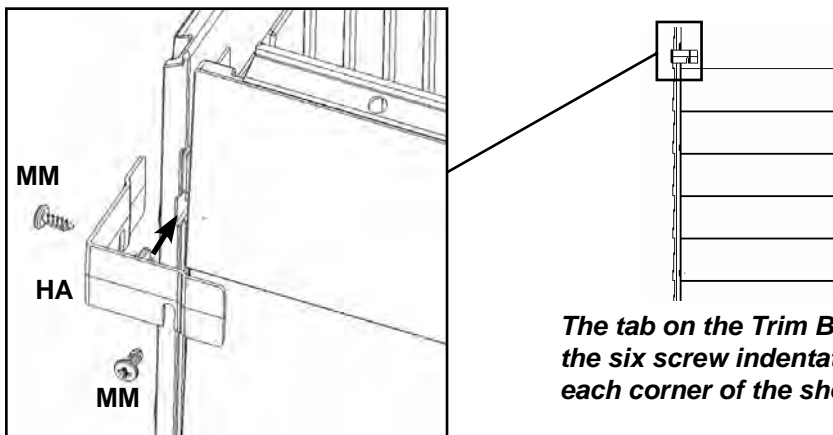

The tab on the Trim Brackets fit into the six screw indentations along each corner of the shed.

Step 10 Hardware

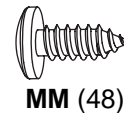

MM (48)

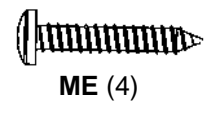

ME (4)

Hardware Bag: 1009129, 1012086
Screwdriver

- 10b Slide a Corner Trim Piece (AL) onto the Brackets. Align the Trim piece with the top of the Wall Panel and Fasten with a #8 Pan-Head Screw (ME). Insert the Screw on the side of the shed so that it will be hidden by the roof overhang.

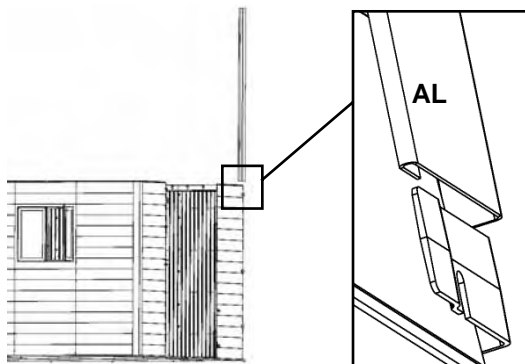

Be Sure that the Corner Trip Piece is even with the front edge of the Wall Panel, before securing with a Screw (ME).

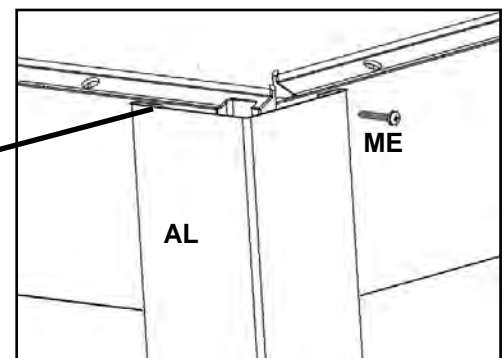

WARNING

Use extreme caution when standing on ladders to perform assembly steps. Follow all warnings and cautions on the ladder. Failure to follow all of these instructions and warnings could lead to serious personal injury or property damage.

Repeat steps 10a and 10b for all four corners.

11 Assemble Windows

Use this step to install windows into both Window Wall Panels (JH).

Step 11 Hardware



PC (4)



MK (4)

Hardware Bag: 1012088
Screwdriver

- 11a From the outside, push two #10 x .38" Flat Head Screws (PC) through the holes in the window divider in Window Wall Panel (JH). Secure with two #10 Cap Nuts (MK).

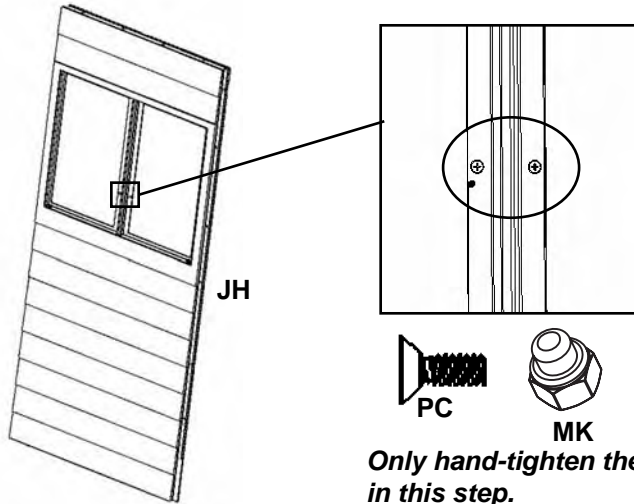

You will need to push the screws through the thin layer of plastic covering the holes.

Only hand-tighten the nuts in this step.

WARNING

Do not overtighten the Cap Nut. If the end of the Bolt breaks through the plastic cap, call our Customer Service Department at the number on Page One. Exposed threads on the end of the Bolt may cause serious injuries.

- 11b Slide Window Hinge Tubes (KF) into the upper and lower hinge holes and fit a Window Frame (JI) over the Hinge Tubes.

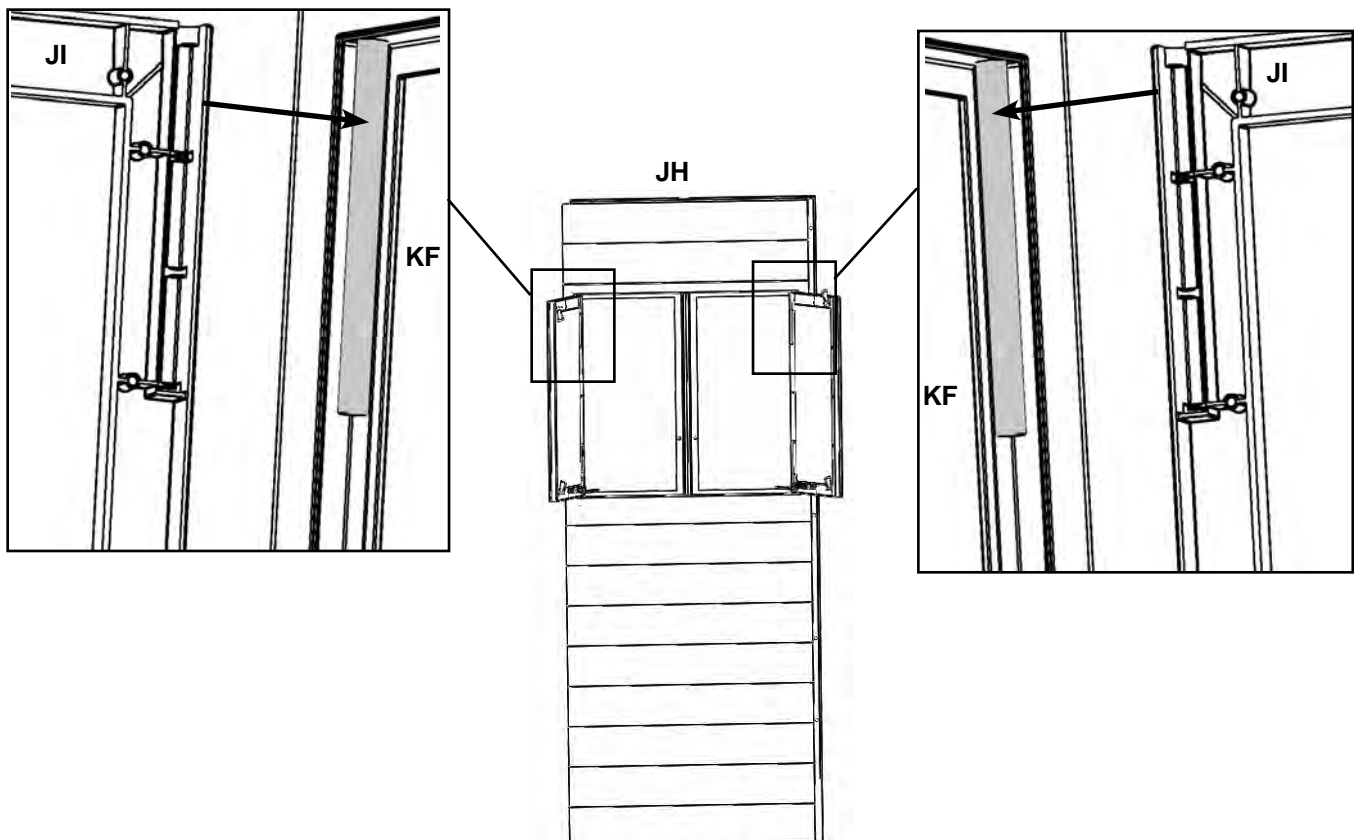

11c Place a Window (JL) onto the Window Frame (JI). Fasten the Window to the Frame with #10 x 1/2" Pan Head Screws (MM) and #10 x 1/2" Flat Head Screws (PB) in the locations shown.

Step 11 Hardware (Continued)

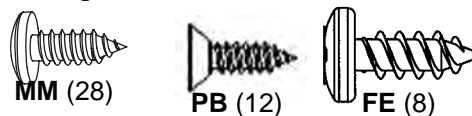

Hardware Bag: 1012088 Screwdriver

Remove plastic film from both sides of window panes before installing.

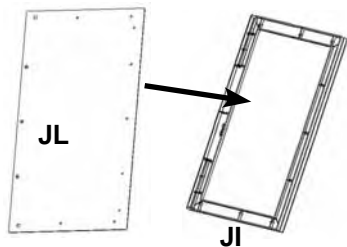

Be sure that the middle holes (circled w/ dashed lines) are beveled inward so that the top of the screw is flush with the window pane when installed.

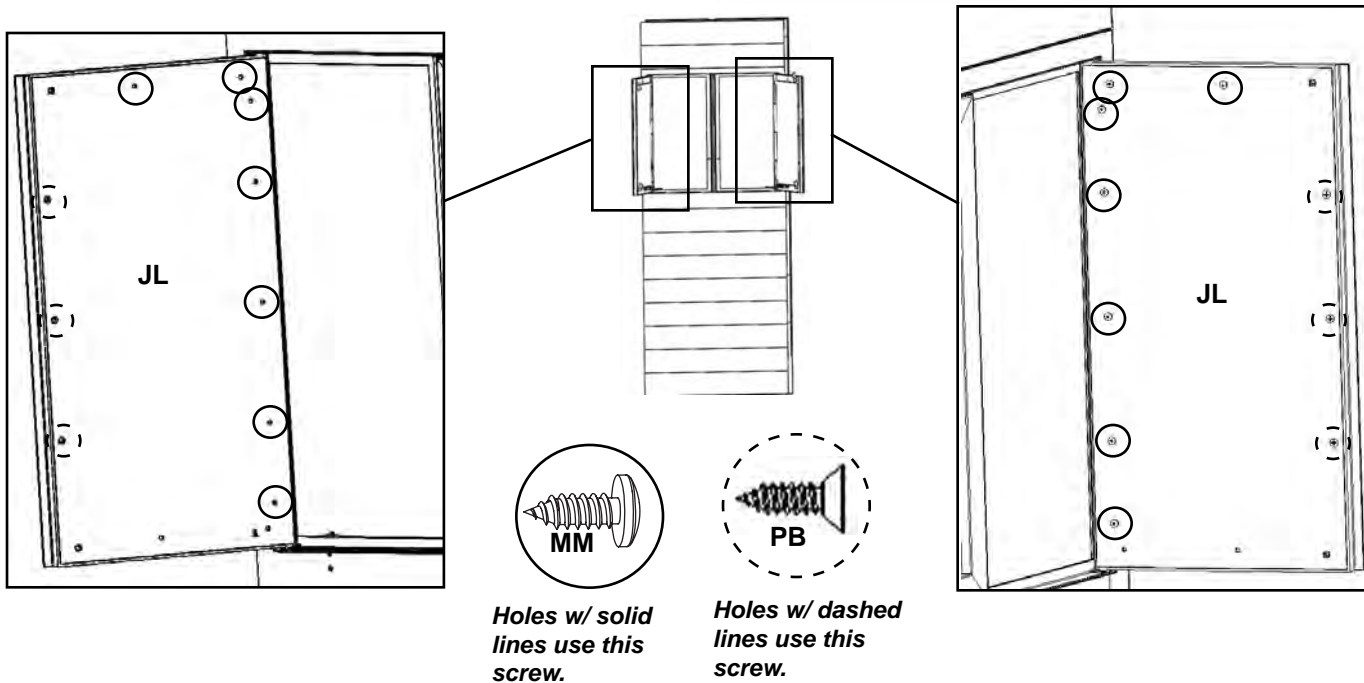

11d Attach a Window Stay Bracket (KA) to the inside of the Window Wall.

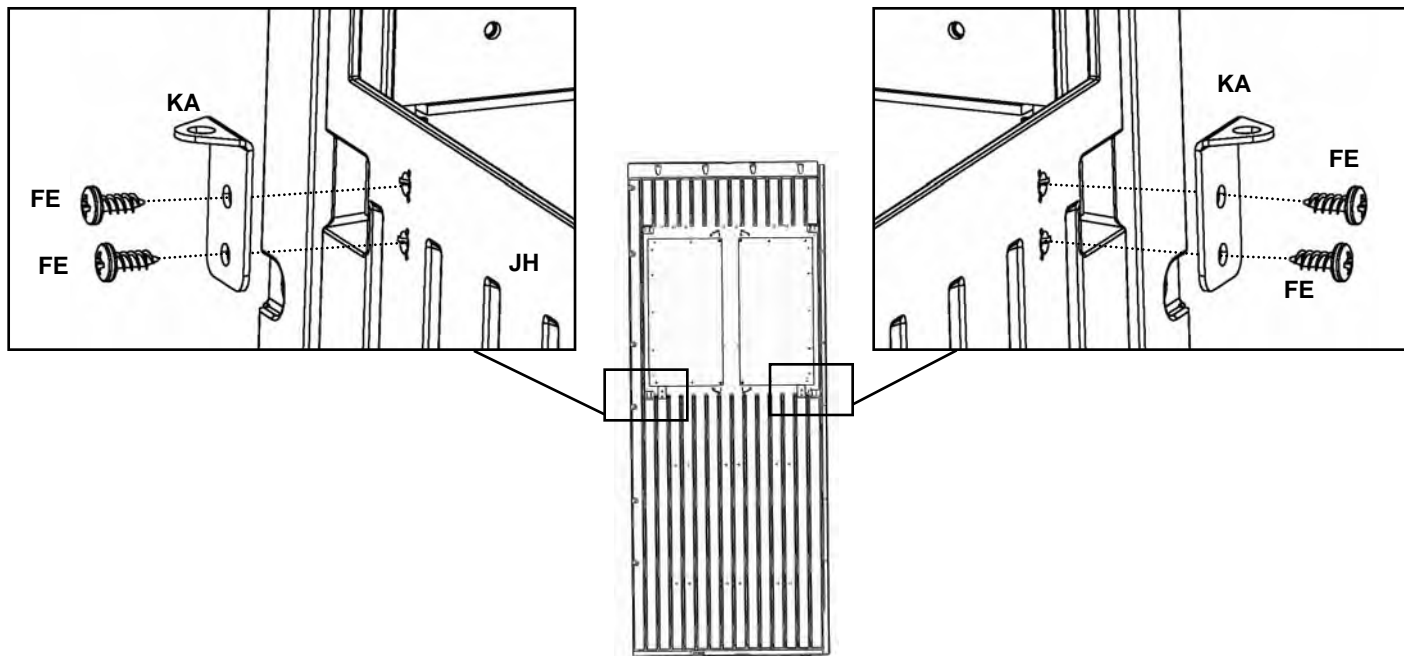

11e Attach a Mounted Window Stay (KB) to the bottom of the Window Frame (JI).

Step 11 Hardware (Continued)

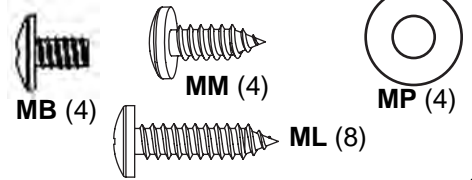

Hardware Bag: 1012088 Screwdriver

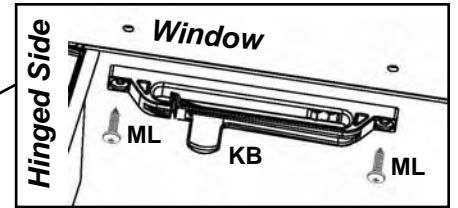
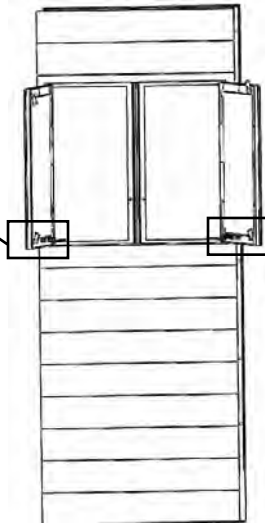
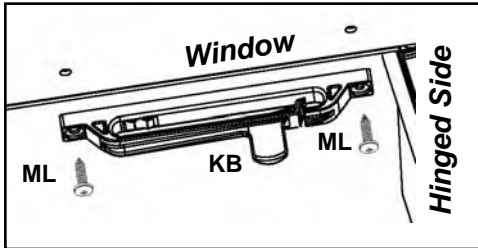

11f Fit a Sliding Window Stay (KC) into the Mounted Window Stay (KB). Secure with Screw (MM).

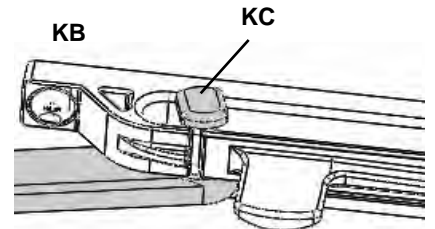
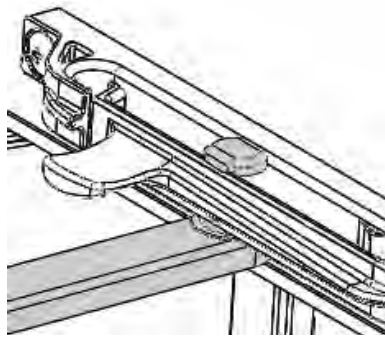
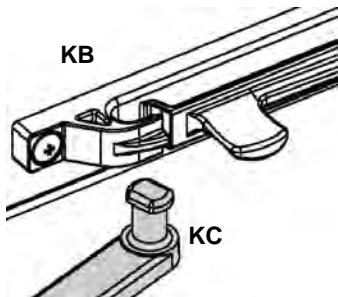

11g Attach a Sliding Window Stay (KC) to the Window Stay Bracket (KA).

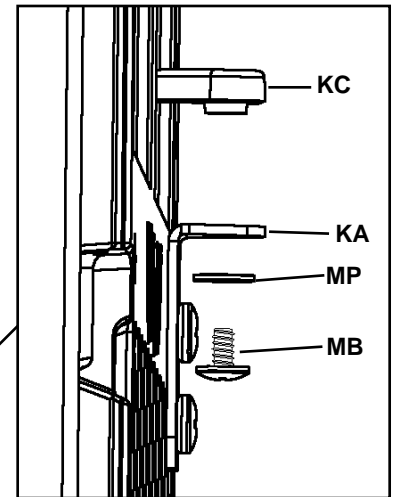
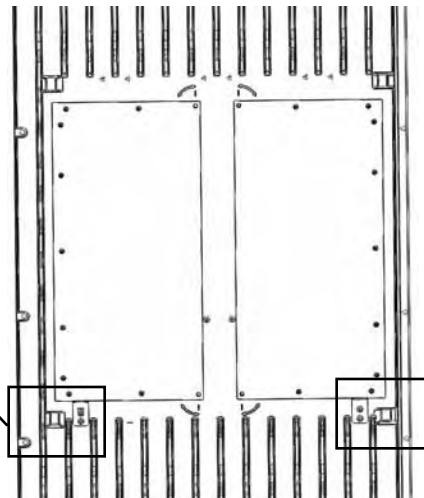
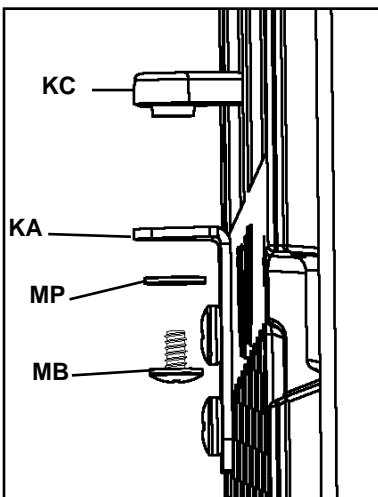

11h Fit a Window Latch Bearing (KD) into a Window Latch (KE). Attach the Window Latch to the upper latch location with a Screw (PA). Repeat for other window latches.

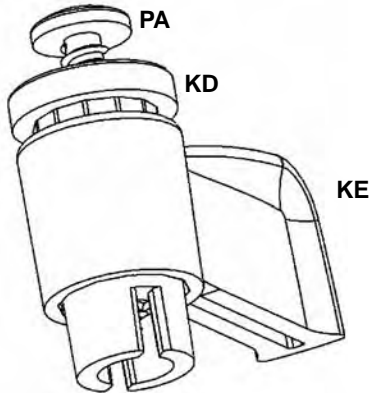

Step 11 Hardware (Continued)

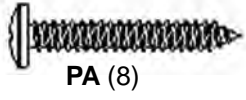

PA (8)

Hardware Bag: 1012088 Screwdriver

Be sure that the Notch in the Window Latch Bearing fits over the Plastic Ridge in the Window Frame.

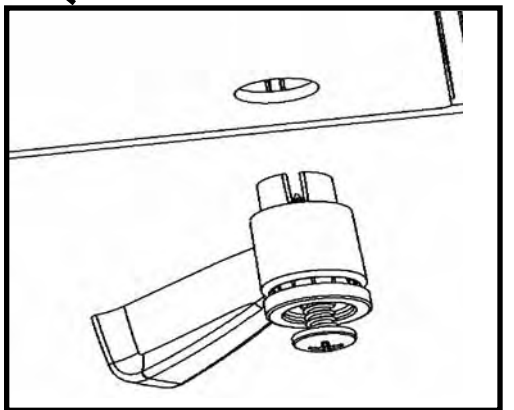
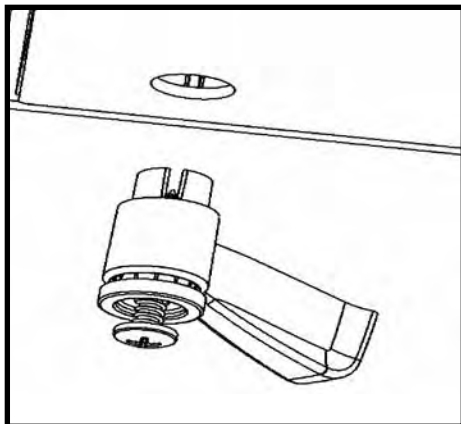
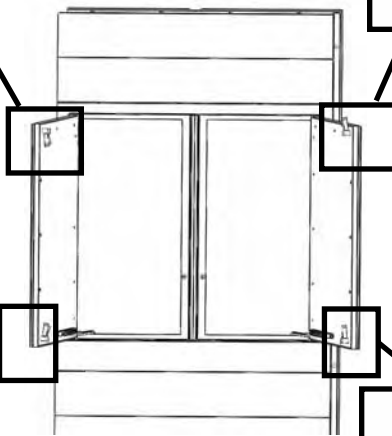
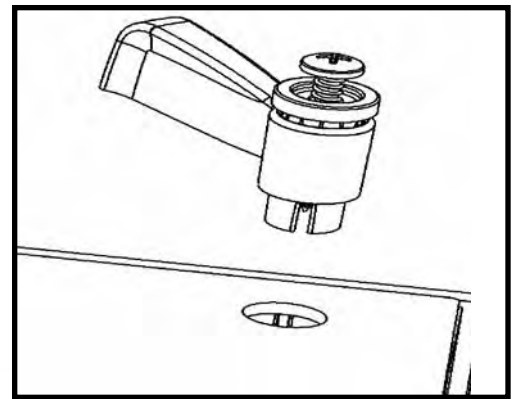
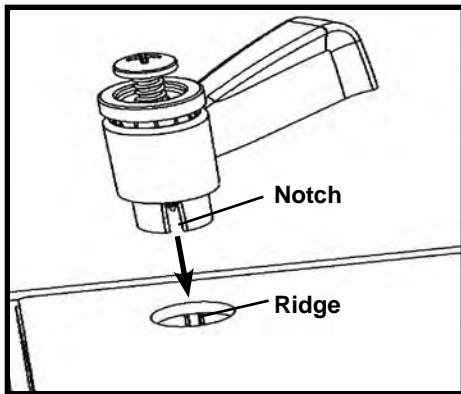

Repeat this section for the second Window Wall Panel and Remaining Windows.

12 Assemble Truss Frames

12a Fit two Truss Support Strips (AV) together. Bolt Truss Support Strips, Center Gutter Connector (FD) and two Gutter Channels (AH).

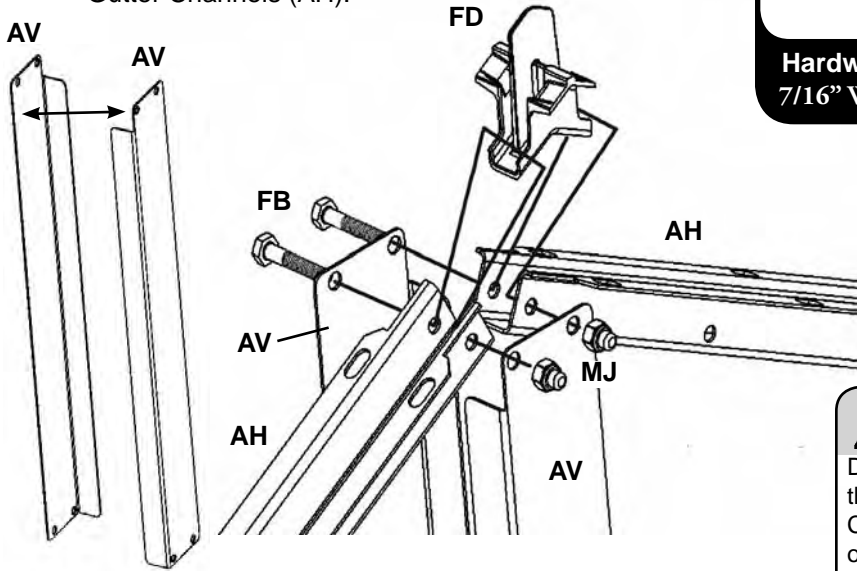

Step 12 Hardware

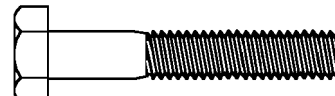

FB (32)



MJ (32)

Hardware Bag: 1013052, 1013053 or 1011614
7/16" Wrench, 7/16" Socket Wrench

*Finger
Tighten
Hardware*

⚠ WARNING ⚠

Do not overtighten the Cap Nut. If the end of the Bolt breaks through the plastic cap, call our Customer Service Department at the number on Page One. Exposed threads on the end of the Bolt may cause serious injuries.

12b Attach a Truss Channel (AM). (Truss Support Strips (AV) fit inside Truss Channel). Attach Truss Channel to Gutter Channel (AH) at each end.

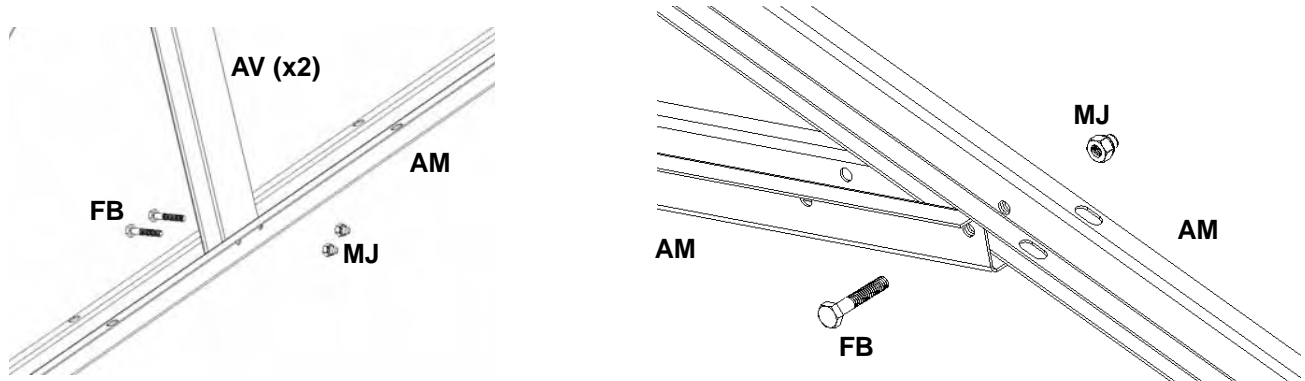

Tighten All Hardware

12c Attach Truss Assembly to two Wall Support Channels (AA). Do not completely tighten the Nut until after truss is secured to the wall.

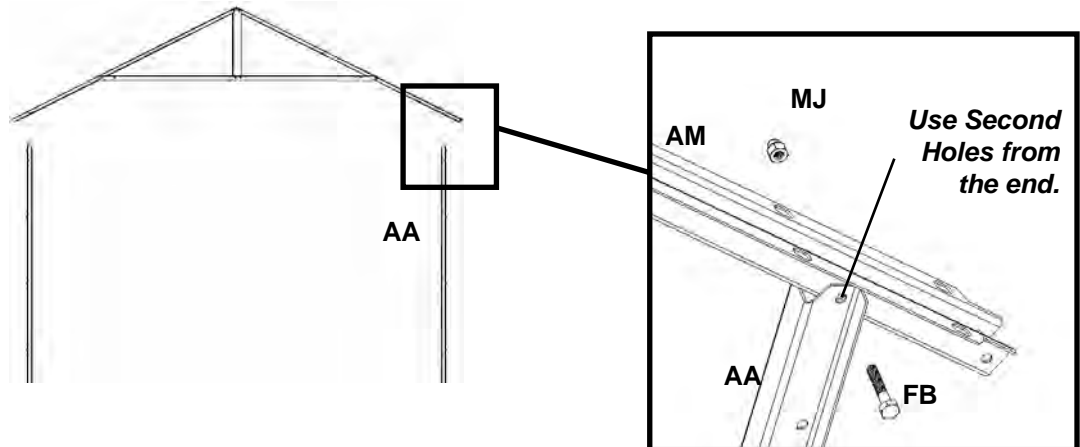

Repeat these steps for all four trusses.

Assembly Tip #5

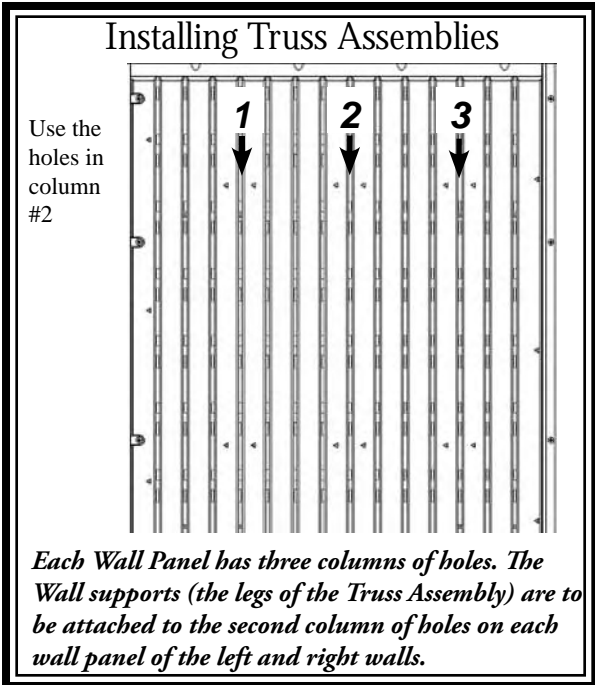

13 Install Truss Assemblies

13a Starting at the back of the shed, secure a Truss Assembly to the center of each wall panel on the Left and Right Walls with Screws (FE). **See Assembly Tip #5 (above).**

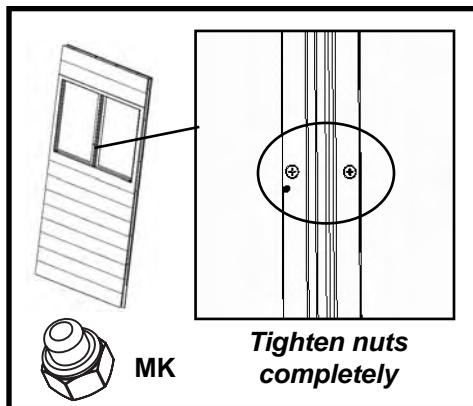
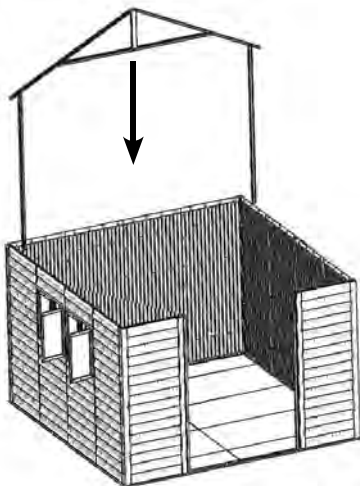

NOTE

At least one truss will fall on the Window Wall Panels. You will need to remove the #10 Cap Nuts (MK) between the windows before installing the Truss(es). Once Truss is in place, replace the Cap Nuts onto the Screws.

Step 13 Hardware

FE (60) **MJ (8)** **FA (8)**

FB (8)

Hardware Bags: 1009126, 1013052, 1013053 or 1011614
Screwdriver, 7/16" Wrench, 7/16" Socket Wrench

13b Attach one Floor Bracket (FA) to each Wall Support Channel (AA) and screw the Bracket to the floor. You only need to do this step if you plan to anchor your shed. See the "Anchoring the Shed" step at the end of this manual.

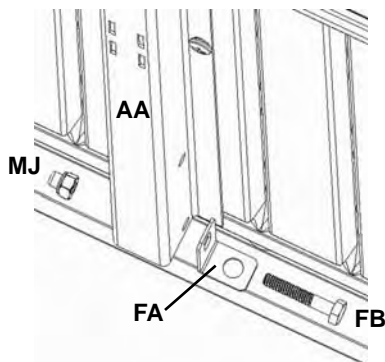

Tighten all Hardware.

⚠ WARNING ⚠

Do not overtighten the Cap Nut. If the end of the Bolt breaks through the plastic cap, call our Customer Service Department at the number on Page One. Exposed threads on the end of the Bolt may cause serious injuries.

14 Left Door Assembly

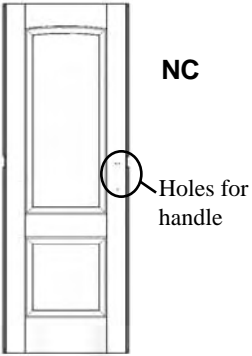

Step 14 Hardware

MC (2) MP (3) FE (9)

MJ (2) ML (3) CA (2)

(Not Actual Size)

Hardware Bags: 1015978, 1012086, 1009126 7/16" Wrench Screwdriver

14a Rest Left Door (NC) with front side down. Position Deadbolt Latches (CA) in slots at top and bottom of door then slide Door End Channel (AY) onto the door.

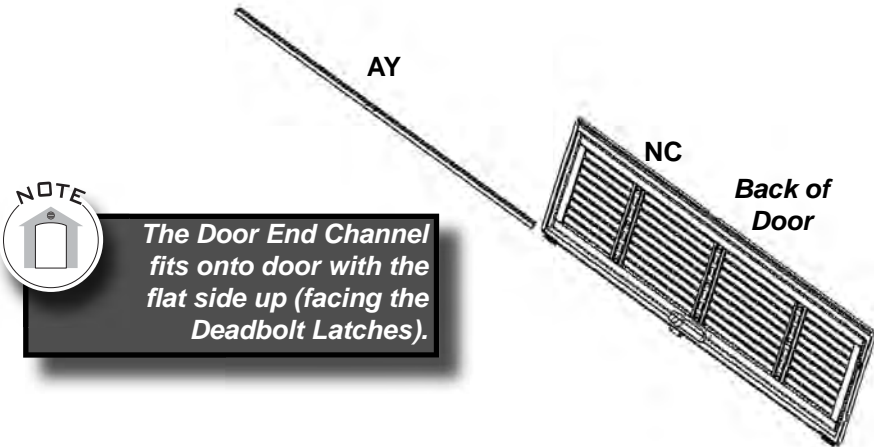

NOTE
The Door End Channel fits onto door with the flat side up (facing the Deadbolt Latches).

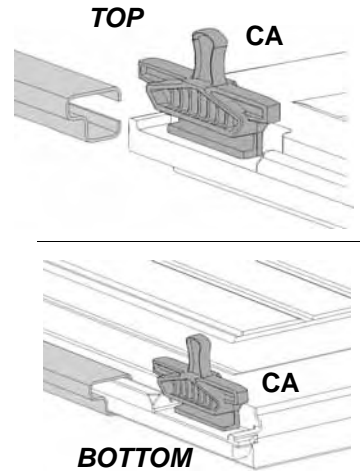

14b Attach three Door Braces (AX) to the back of the door with 1/4" x 5/8" Screws (FE).

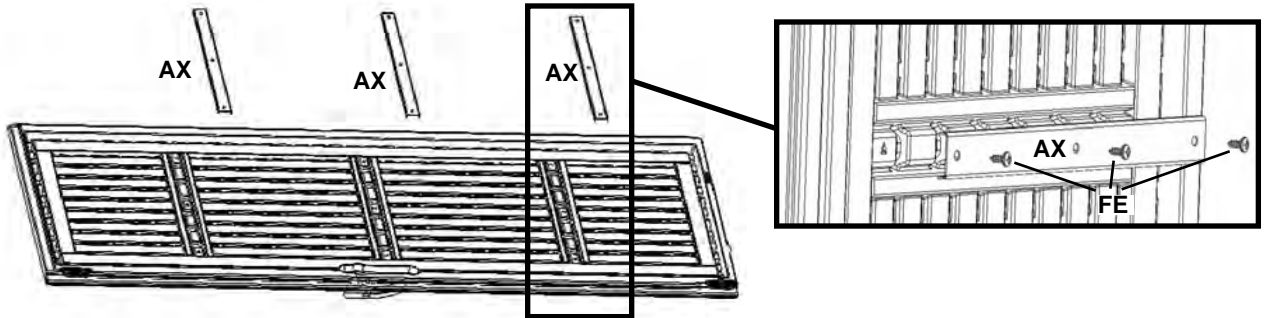

14c Install Left Door Handle (BC). Set door aside.

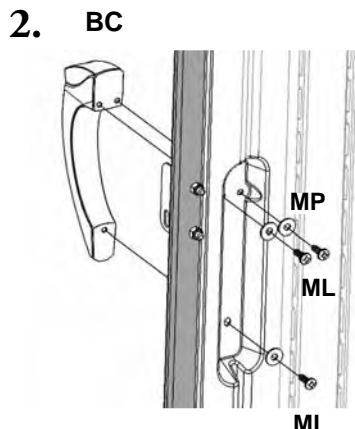
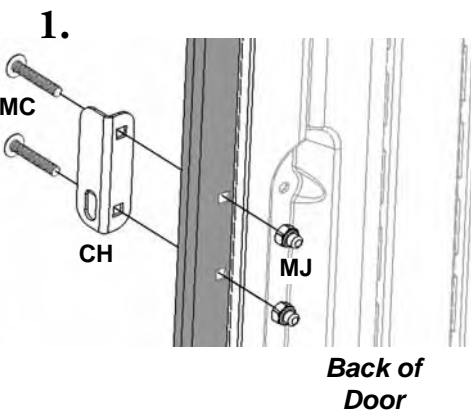

NOTE
You may need to nudge the Door End Channel to make these holes line up with the gap in the door.

CAUTION
Do not overtighten. Overtightening may damage parts and void warranty.

Tighten All Hardware

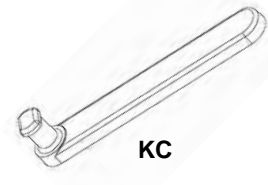
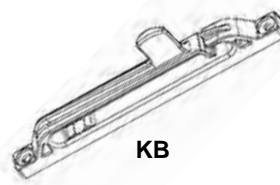
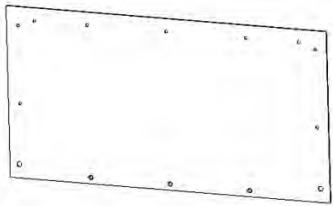
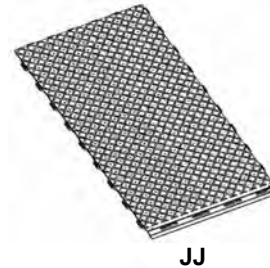
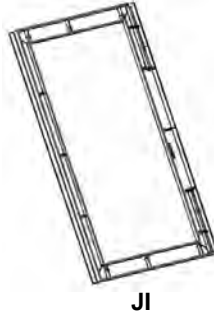
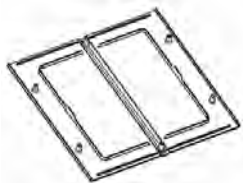
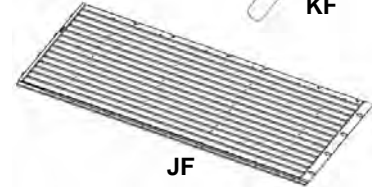
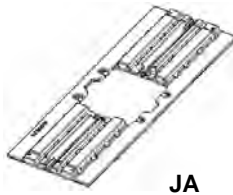
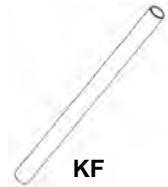
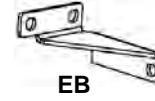
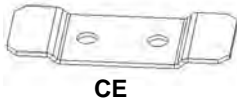
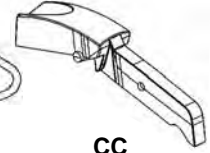
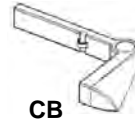
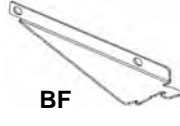
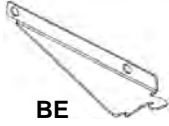
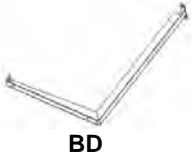
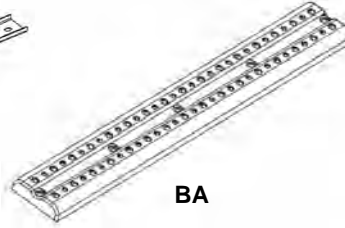
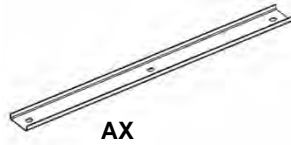
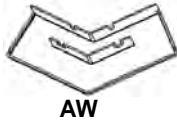

PULL OUT THIS PAGE
FOR EASY REFERENCE

Parts List

Box 1

ID	Part #	Description	Qty
Main Hardware			
AA	1007977	Wall Support Channel	8
AB	1009339	10" Shelf	5
AC	1007979	Outer Roof Panel A	2
AD	1009352	14" Shelf	2
AE	1007981	Long Vertical Extension Channel	2
AF	1007982	Gable Side B	2
AG	1007983	Outer Roof Panel B	2
AH	1007984	Gutter Channel	2
AI	1007985	Corner Channel	4
AJ	1007986	Short Vertical Extension Channel	4
AK	1009522	Door Header Channel	1
AM	1007988	Truss Channel	1
AN	1007989	Gable Side A	2
AO	1007990	Outer Floor Panel B	2
AP	1007991	Outer Floor Panel A	2
AQ	1007992	End Roof Cap	2
AT	1009573	Right Door Hinge	1
AU	1009575	Left Door Hinge	1
AV	1009156	Truss Support Strip	2
AX	1009489	Door Brace	6
AY	1009606	Door End Channel	2
BD	1009335	Gable Truss Brace	2
Shed Parts Box [1016071]			
BA	1009266	16" Pegboard Strip	2
BB	1015792	Right Door Handle	1
BC	1009123	Left Door Handle	1
BE	1009118	10" Shelf Bracket	10
BF	1009119	14" Shelf Bracket	4
AW	1009488	Roof Cap Cover	2
BG	1010271	1 1/4" Foam Cube	20
Shed Door Parts Bag [1015978]			
CA	CH11999	Deadbolt Latch	2
CB	AC00100	Latch	1
CC	1015832	Thumb Lever	1
CD	1009172	Door Floor Bracket	2
CE	1009199	Door Trim Bracket	4
CF	1009201	Latch Cover Plate	1
CG	1009202	Right Door Latch	1
CH	1009203	Left Door Latch	1
CJ	1009230	Dead Bolt Strike Plate	1
CK	1011133	Door Trim Clip	2
Shed Door Hardware Bag [1012086]			
MA	1005443	1/4" x 1/2" Carriage Bolt	4
MB	1008533	#10 x 5/16" Pan Head Screw	1
MC	1009197	1/4" x 1 1/2" Carriage Bolt	6
MD	1009210	1/4" x 2" Carriage Bolt	2
ME	1011132	#8 x 1" Pan-Head Screw	4
MF	300022	1/4" Centerlock Nut	2
MG	BA05700	.375" x .58" Steel Spacer	2
MH	BG01600	Door Mechanism Spring	1
MJ	BN00300	1/4" Cap Nut	10
MK	BN01600	#10 Cap Nut	1
ML	BS05800	#10 x 3/4" Pan-Head Screw	6
MM	BS05900	#10 x 1/2" Pan-Head Screw	11
FE	BS07500	1/4" x 5/8" Screw	3
MN	BW00300	1/4" Flat Washer	4
MP	BW01300	#10 Washer	6
Vent Hardware Bag [1009159] x2			
DA	1009158	Louvered Vent	1
DB	DA03700	Vent Screen	1
ML	BS05800	#10 x 3/4" Pan-Head Screw	6
MP	BW01300	#10 Washer	6

Shed Ends Hardware Bag [1009126]			
FE	BS07500	1/4" x 5/8" Screw	280
Shelf Hardware Bag [1009125]			
MM	BS05900	#10 x 1/2" Pan Head Screw	51
EB	1009115	Back Shelf Bracket	7
MP	BW01300	#10 Washer	30
Truss Hardware Bag [1013052]			
FA	1009117	Floor Bracket	8
FB	300072	1/4" x 1.5" Hex Bolt	29
MJ	BN00300	1/4" Cap Nut	29
FD	1012933	Center Gutter Connector	1
Tool Clip Assortment [HH12500]			
GA	BA06500	Pegboard J-Hook	3
GB	BA06600	Pegboard L-Hook	3
GC	BA06700	Pegboard Toolholder	2
GD	BA06800	Pegboard 2" Double Arm Hook	1
GE	BA06900	Pegboard 4" Double Arm Hook	1
Shed Trim Hardware Bag [1009129]			
HA	1009116	Black Trim Bracket	24
MM	BS05900	#10 x 1/2" Pan Head Screw	48

Box 2

JA	1007995	Center Roof Cap	2
AH	1007984	Gutter Channel	4
AA	1007977	Wall Support Channel	4
AM	1007988	Truss Channel	2
JE	1007996	Inner Roof Panel	4
JF	1007997	Wall Panel	3
JG	1009232	Skylight	2
JH	1007998	Window Wall Panel	1
JI	1007999	Window Frame C	2
JJ	1008000	Inner Floor Panel	4
JK	1008001	Roof Support Strip	8
JL	1013660	Window C	2
AV	1009156	Truss Support Strip	4
Shed Parts Box [1012799]			
Window Parts Hardware Bag [1012087]			
KA	1009211	Window Stay Bracket	2
KB	1009212	Mounted Window Stay	2
KC	1009213	Sliding Window Stay	2
KD	1014093	Window Latch Bearing	4
KE	1009215	Window Latch	4
KF	1004592	Window Hinge	4
Window Hardware Bag [1012088]			
PA	1005981	#10 x 1 1/4" Pan Head Screw	4
PB	1005982	#10 x 1/2" Pan Head Screw	6
PC	1005984	#10 x .38" Flat Head Screw	2
MB	1008533	#10 x 5/16" Pan Head Screw	2
MK	BN01600	#10 Cap Nut	2
ML	BS05800	#10 x 3/4" Pan-Head Screw	9
MM	BS05900	#10 x 1/2" Pan Head Screw	16
FE	BS07500	1/4" x 5/8" Screw	4
MP	BW01300	#10 Washer	4
Skylight Hardware Bag [1010047]			
LA	BW01200	#10-1" Fender Washer	13
LB	1010132	#10 x 5/8" Pan Head Screw	13
Truss Extension Hardware Bag [1013053]			
FA	1009117	Floor Bracket	4
FB	300072	1/4" x 1 1/2" Hex Bolt	21
MJ	BN00300	1/4" Cap Nut	21
FD	1012933	Center Gutter Connector	2
Shed Screw Hardware Bag [1011135]			
FE	BS07500	1/4" x 5/8" Screw	118

PULL OUT THIS PAGE

Box 3

JA	1007995	Center Roof Cap	1
AH	1007984	Gutter Channel	2
AA	1007977	Wall Support Channel	2
AM	1007988	Truss Channel	1
JE	1007996	Inner Roof Panel	2
JF	1007997	Wall Panel	1
JG	1009232	Skylight	1
JH	1007998	Window Wall Panel	1
JI	1007999	Window Frame C	2
JJ	1008000	Inner Floor Panel	2
JK	1008001	Roof Support Strip	4
JL	1013660	Window C	2
AV	1009156	Truss Support Strip	2

Shed Parts Box [1014608]

Window Parts Hardware Bag [1012087] 1

KA	1009211	Window Stay Bracket	2
KB	1009212	Mounted Window Stay	2
KC	1009213	Sliding Window Stay	2
KD	1014093	Window Latch Bearing	4
KE	1009215	Window Latch	4
KF	1004592	Window Hinge	4

Window Hardware Bag [1012088] 1

PA	1005981	#10 x 1 1/4" Pan Head Screw	4
PB	1005982	#10 x 1/2" Pan Head Screw	6
PC	1005984	#10 x .38" Flat Head Screw	2
MB	1008533	#10 x 5/16" Pan Head Screw	2
MK	BN01600	#10 Cap Nut	2
ML	BS05800	#10 x 3/4" Pan-Head Screw	9
MM	BS05900	#10 x 1/2" Pan Head Screw	16
FE	BS07500	1/4" x 5/8" Screw	4
MP	BW01300	#10 Washer	4

Skylight Hardware Bag [1011616] 1

LA	BW01200	#10-1" Fender Washer	7
LB	1010132	#10 x 5/8" Pan Head Screw	7

Truss Extension Hardware Bag [1014607] 1

FA	1009117	Floor Bracket	2
FB	300072	1/4" x 1 1/2" Hex Bolt	11
MJ	BN00300	1/4" Cap Nut	11
FD	1012933	Center Gutter Connector	1

Shed Screw Hardware Bag [1011615] 1

FE	BS07500	1/4" x 5/8" Screw	60
----	---------	-------------------	----

Box 4

JF	1007997	Wall Panel	8
NB	1009133	Right Shed Door	1
NC	1009134	Left Shed Door	1
AL	1007987	Corner Trim Piece	4
AR	1007993	Door Top Trim	1
AS	1007994	Door Trim A	2

Shed Hardware

(Actual Size)

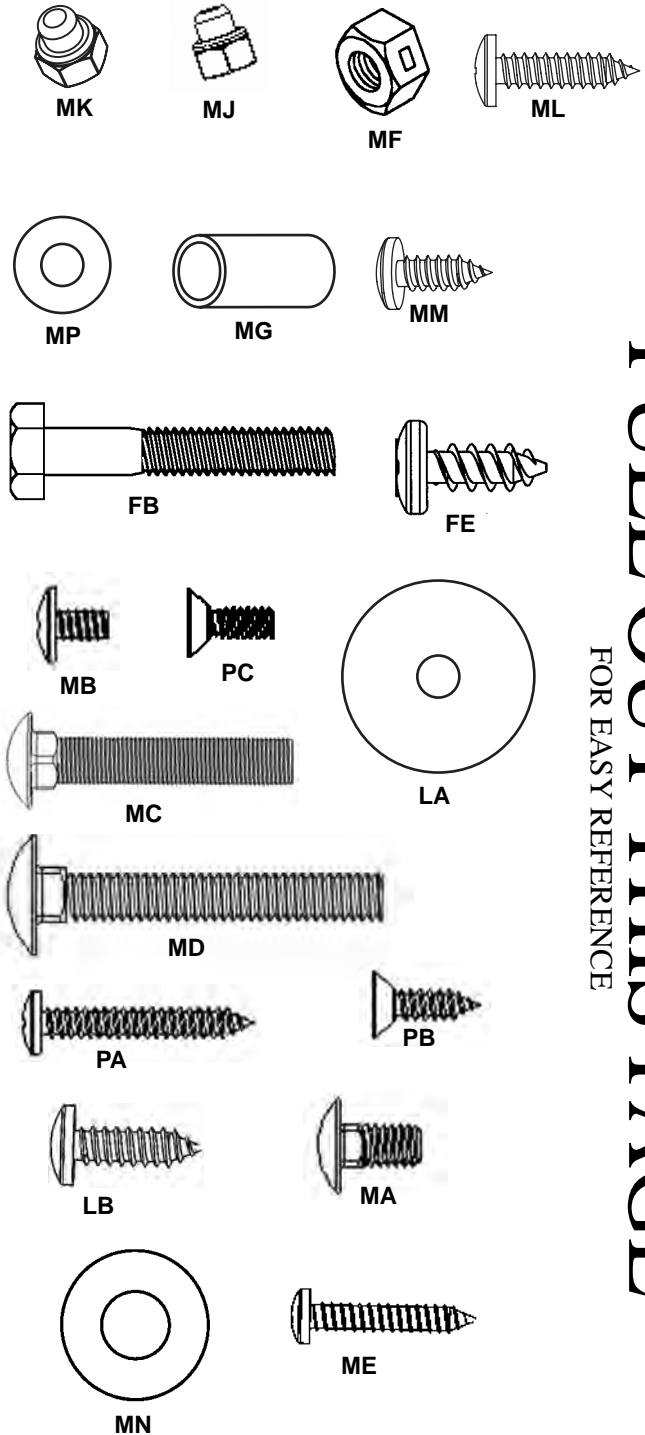

PULL OUT THIS PAGE FOR EASY REFERENCE

Contact our Customer Service Department for questions about replacement parts:

1 (800) 225-3865

**** Customers outside of the U.S. or Canada, please contact the store for assistance. ****

PULL OUT THIS PAGE
FOR EASY REFERENCE

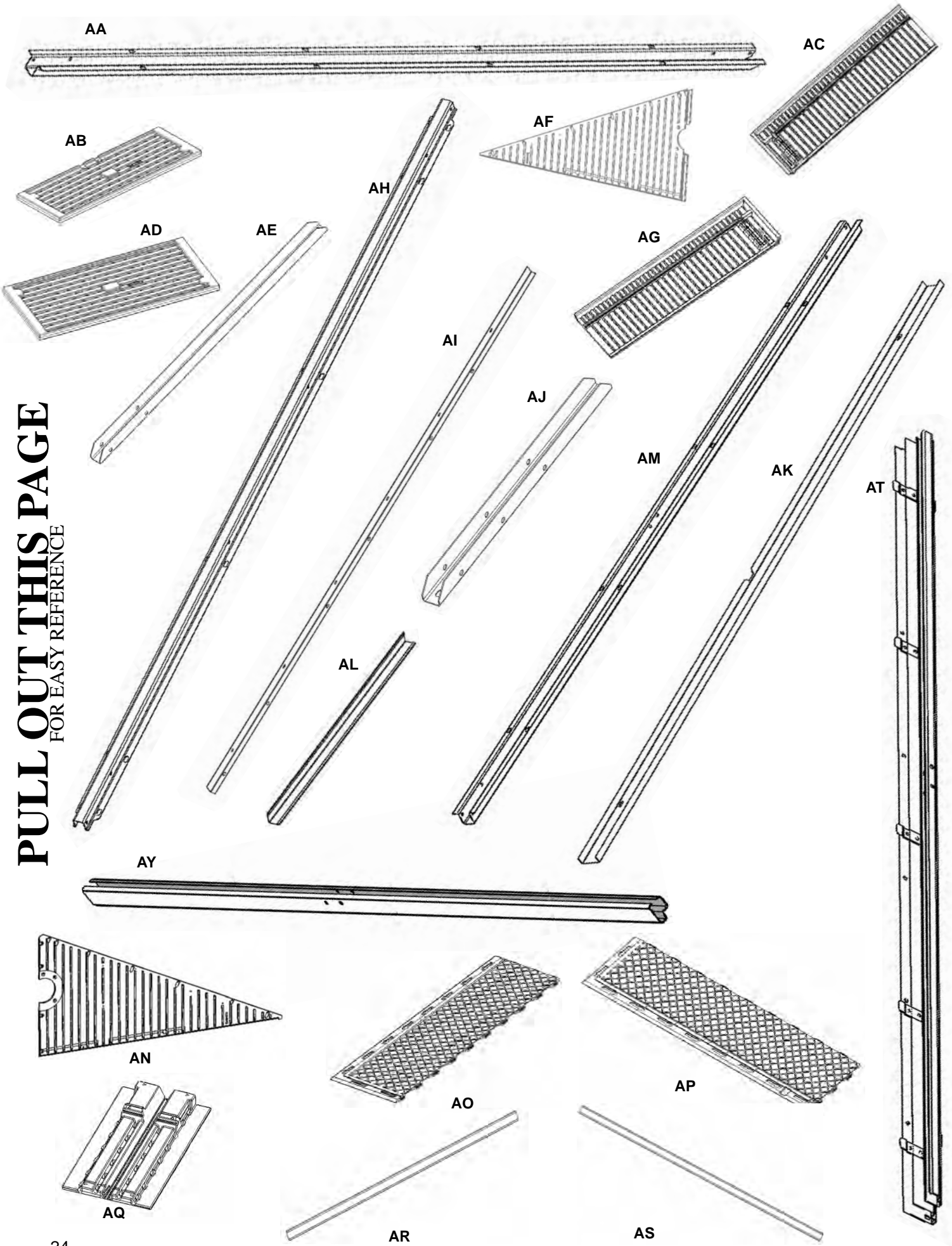

15 Right Door Assembly

15a Rest Right Shed Door (NB) with front side down, then slide Door End Channel (AY) onto the door.

Step 15 Hardware

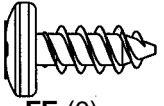

FE (9)

Hardware Bags: 1009126
Screwdriver 7/16" Wrenches (2)

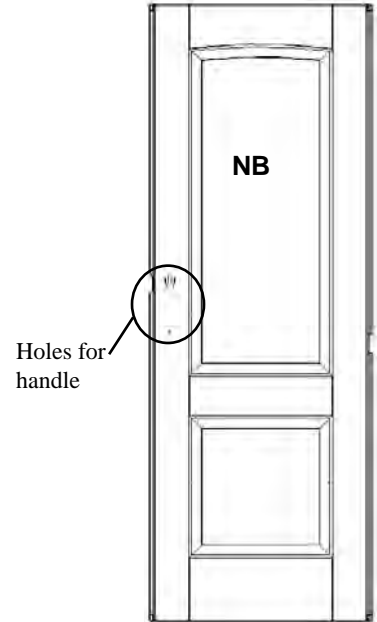
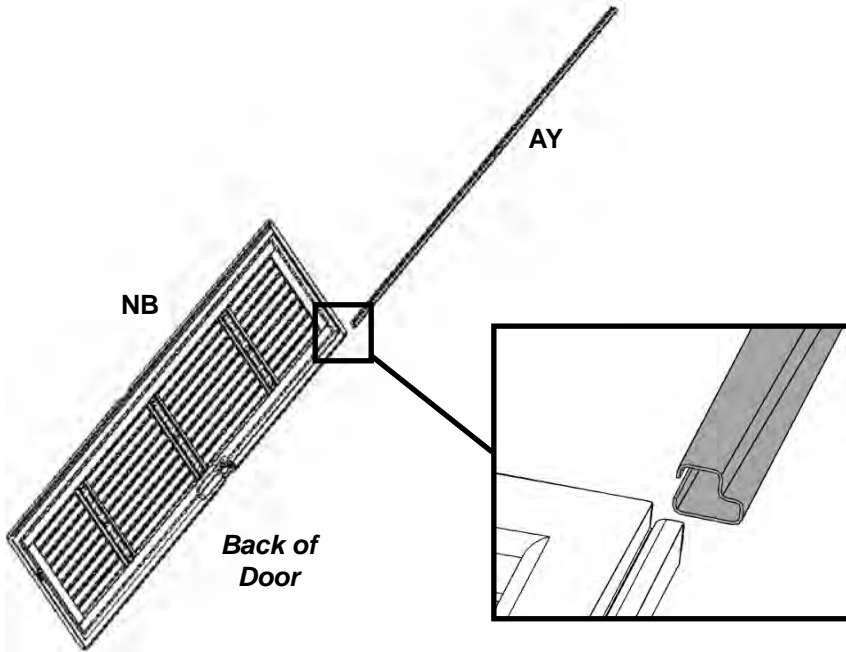

15b Attach three Door Braces (AX) to the back of the door with 1/4" x 5/8" Screws (FE).

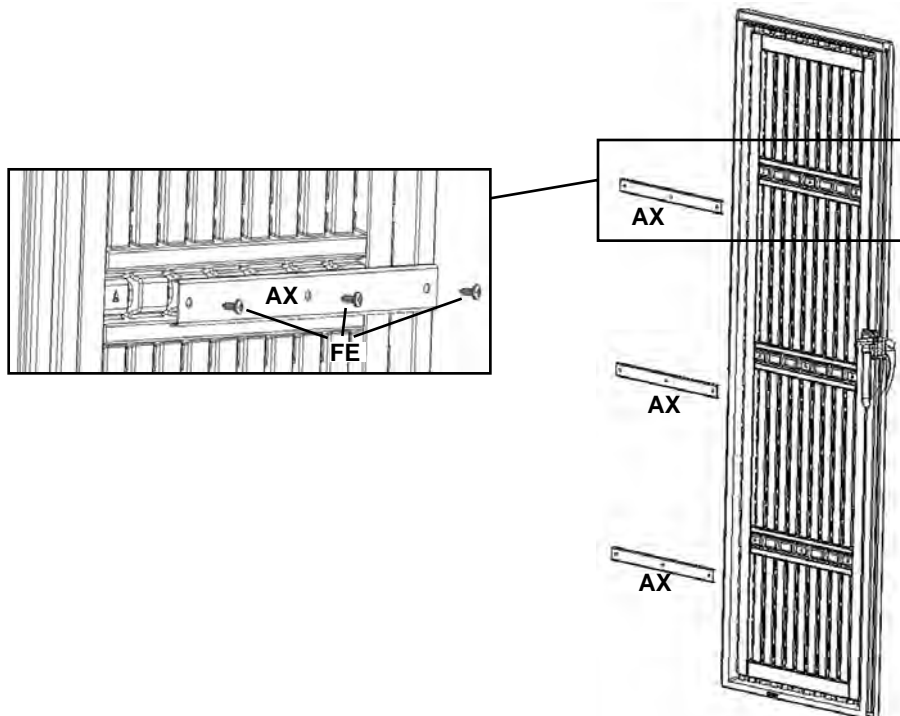

Step 15 Hardware (Continued)

Hardware Bags: 1012086 Screwdriver 7/16" Wrench

15c

1. Fit Thumb Lever Knobs into Handle Grooves.

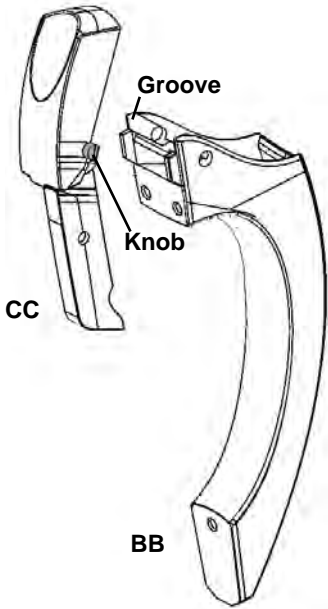

2. Rotate the Thumb Lever into the handle. Slide forward until the Knobs fit into the holes in the handle.

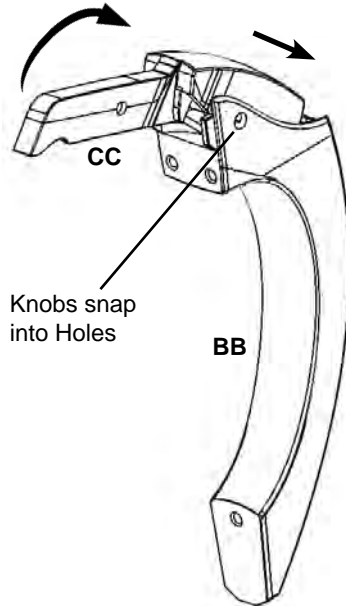

3.

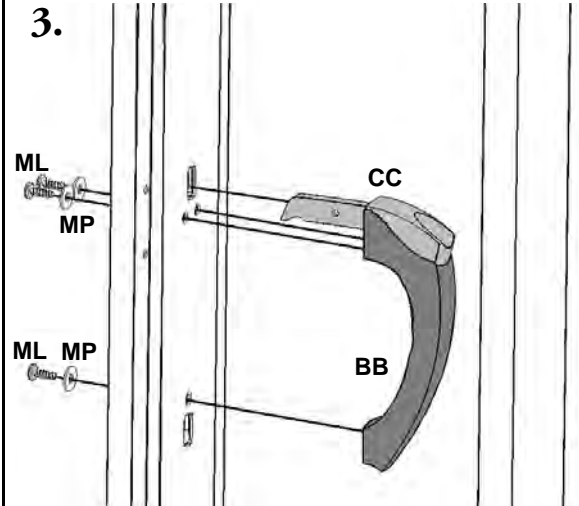

Attach the Handle and Thumb lever to the Door.

4.

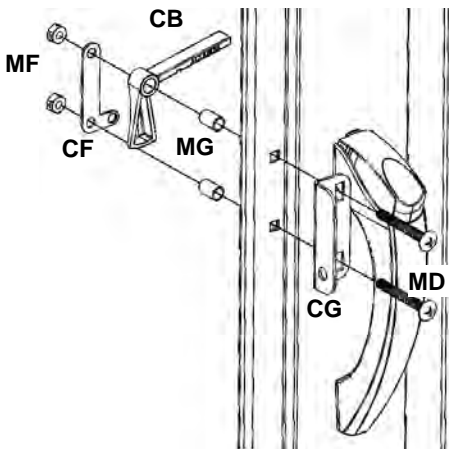

Tighten All Hardware

15d

Attach Door Mechanism Spring (MH) to handle assembly. Set the door aside.

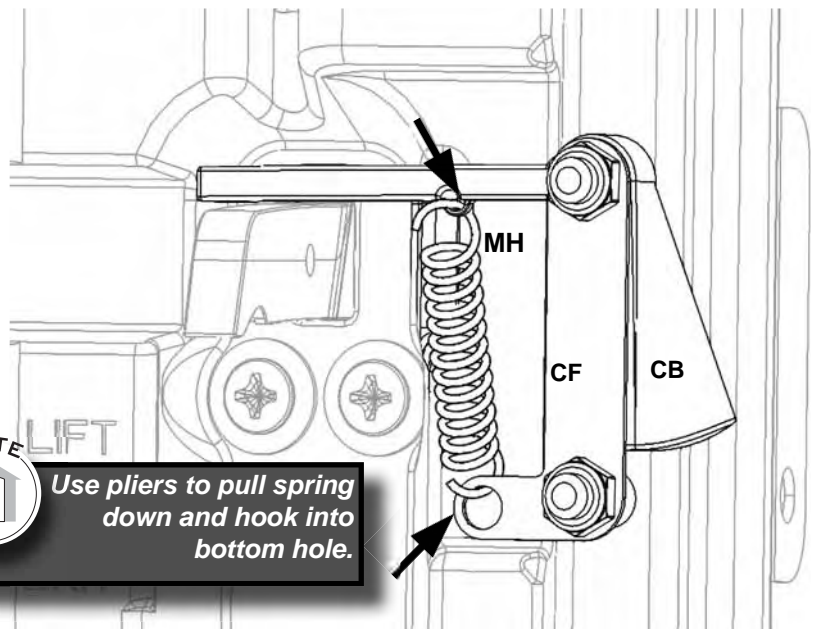

NOTE
Use pliers to pull spring down and hook into bottom hole.

16 Assemble Gables

16a Assemble two halves A and B of a Gable (AF & AN).

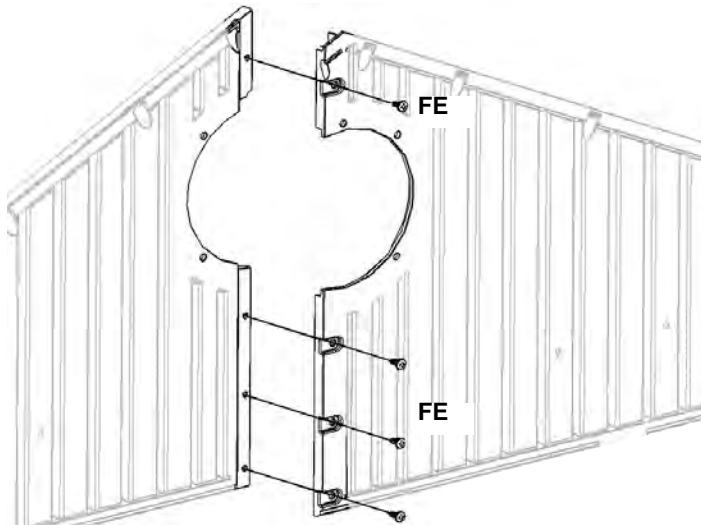

Step 16 Hardware

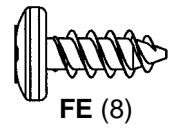
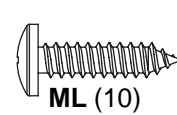

Hardware Bags: 1009159, 1009126
Screwdriver

Assembly Tip #6

Installing Vent and Screen

- To avoid bunching up screen during installation:*
- 1. Put Vent and Screen in place.*
 - 2. Only tighten screws half-way when you put screws and washers in place.*
 - 3. Tighten all screws*

16b Install Vent into the Rear Gable. Set Rear Gable aside until later.

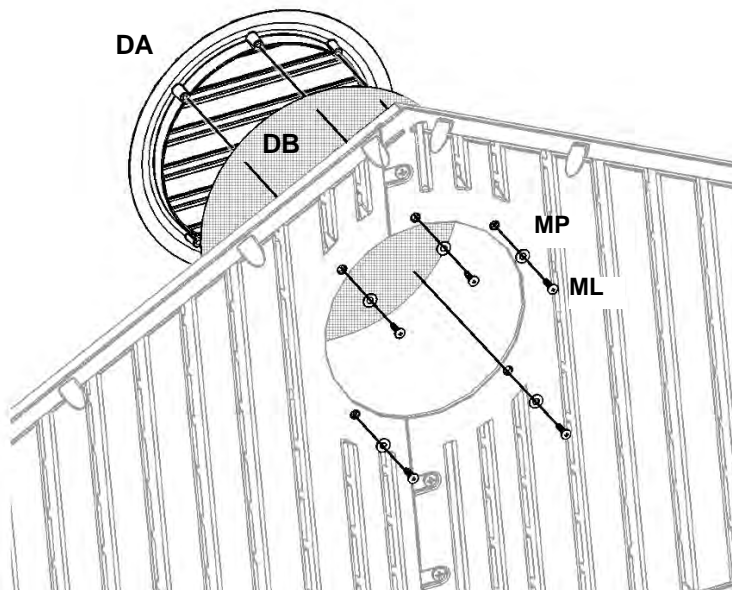

Second person should apply pressure on opposite side of the wall for easy insertion of screws.

Repeat for other Gable

17 Assemble & Install Wall Support Channels

BUILD TWO SUPPORTS:

17a Attach a Short Vertical Extension Channel (AJ) to a Wall Support Channel (AA). Be sure that the Extension Channel is installed in the correct direction. Repeat.

Step 17 Hardware

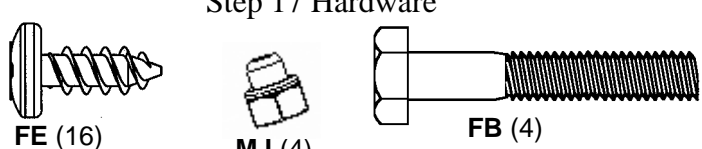

FE (16) MJ (4) FB (4)

Hardware Bags: 1013052, 1009126, 1013053 or 1011614
Screwdriver, 7/16" Wrenches (2)

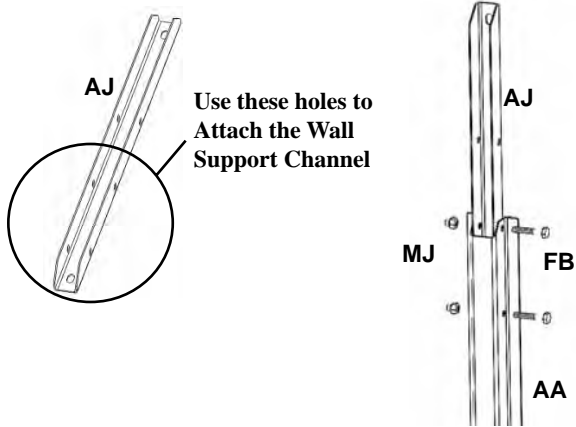

17b Install the Wall Supports with Extension Channels on the Front Wall at the locations shown. Do not completely tighten the screws until after the Front Gable is installed.

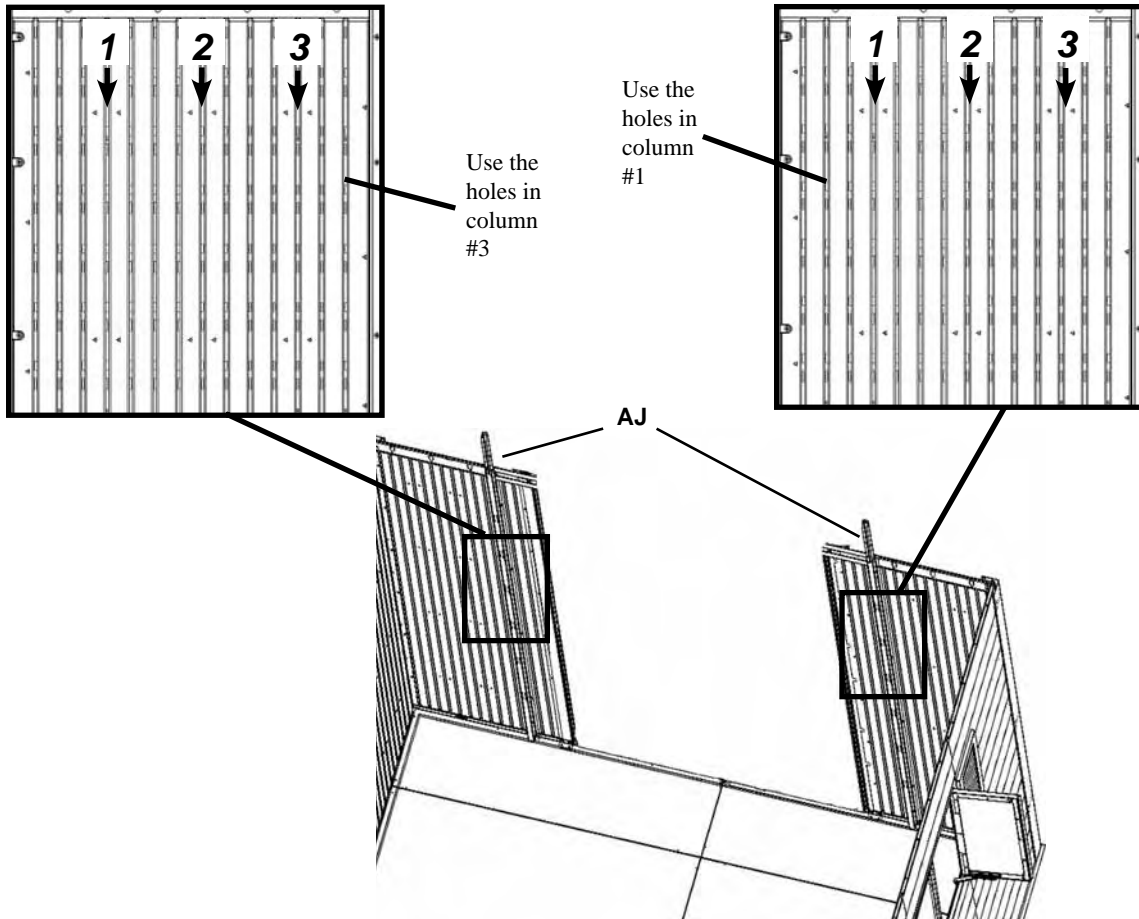

18 Install Front Gables

- 18a Set a Gable on the top of the Front Wall and screw into place. Also screw the Vertical Extension Channels (AJ) into the Gable.

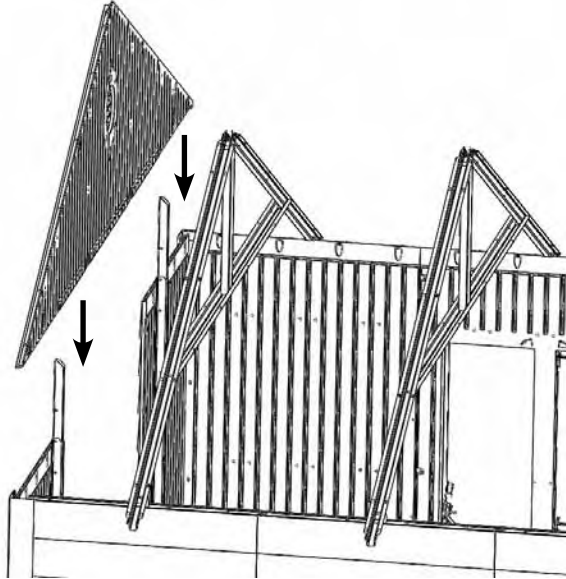

Tighten the Screws on the Wall Supports after the Gable is installed.

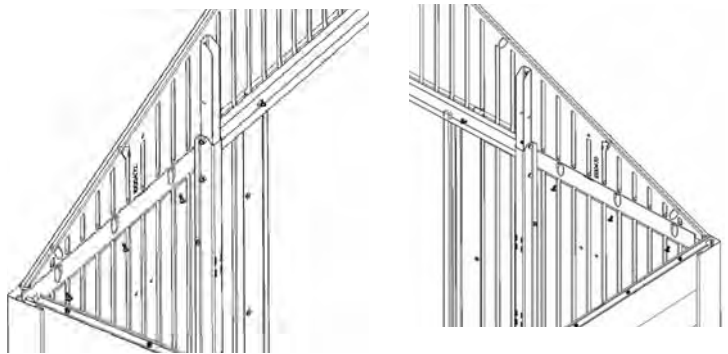

Step 18 Hardware



Hardware Bags:
1009126

Screwdriver

19 Install Door Frame & Doors

- 19a Insert Carriage Bolt (MA) into Door Frame Floor Bracket (CD) and the bottom of the Left Door Hinge (AU). Place a Cap Nut (MJ) loosely on the end of the Carriage Bolt. Repeat for the Right Door Hinge (AT).

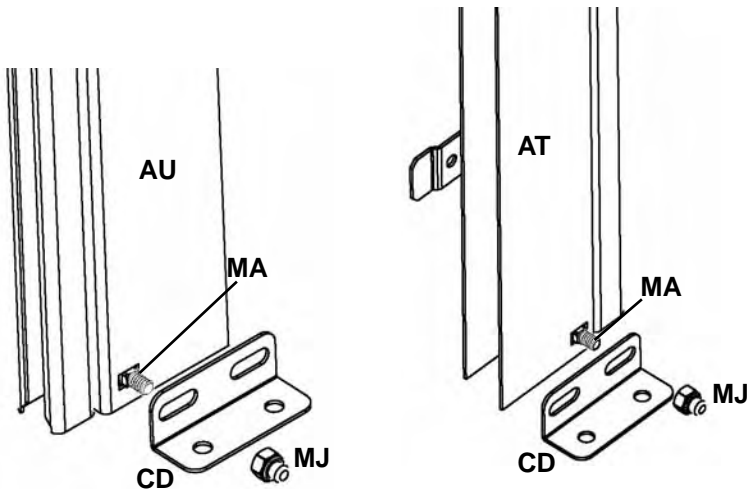

Step 19 Hardware



Hardware Bags: 1012086
7/16" Wrench

⚠ WARNING ⚠

Do not overtighten the Cap Nut. If the end of the Bolt breaks through the plastic cap, call our Customer Service Department at the number on Page One. Exposed threads on the end of the Bolt may cause serious injuries.

Assembly Tip #7

Identify Left and Right Door Hinges

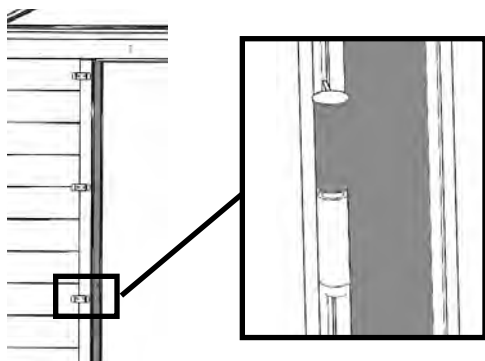

Each hinge has two components. A wider Wall channel that fits over the wall, and a thinner Door Channel that holds the Door. When installed correctly the "Door Channel" hinge will be above the "Wall Channel" hinge.

WARNING

Do not overtighten the Cap Nut. If the end of the Bolt breaks through the plastic cap, call our Customer Service Department at the number on Page One. Exposed threads on the end of the Bolt may cause serious injuries.

19b Push a Carriage Bolt (MA) through the hole in the top of the hinge and loosely place a 1/4" Cap Nut (MJ) on the bolt. Put the Left Door Hinge (AU) into position. Repeat for the Right Door Hinge (AT).

Step 19 Hardware (continued)

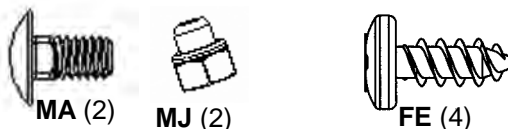

Hardware Bags: 1012086, 1009126 Screwdriver

Left Door Hinge

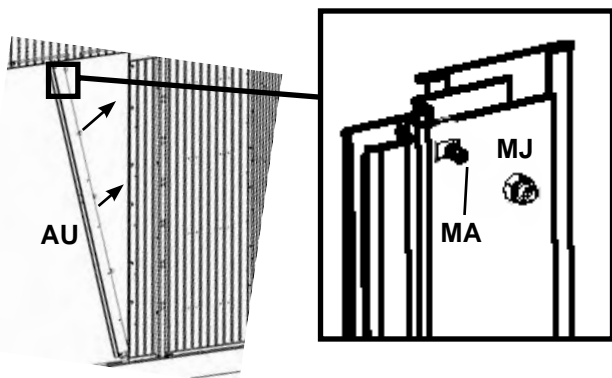

Right Door Hinge

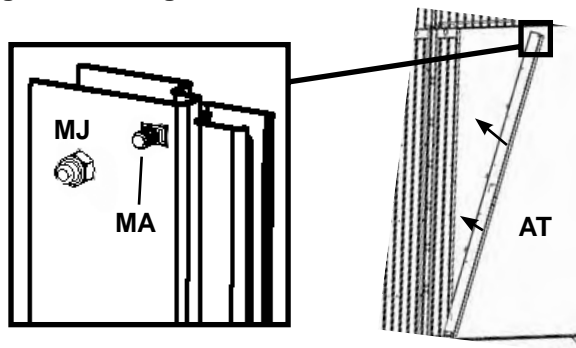

19c While one person holds the Door Header Channel (AK) in place, remove the Cap Nut (MJ) and slide the Door Header Channel (AK) over the bolt. Replace and tighten the Cap Nut (MJ). Remove the Cap Nut (MJ) and slide the Door Header Channel (AK) over the Carriage Bolt (MA). Replace and tighten the Cap Nut (MJ). Screw the Door Header Channel to the Gable.

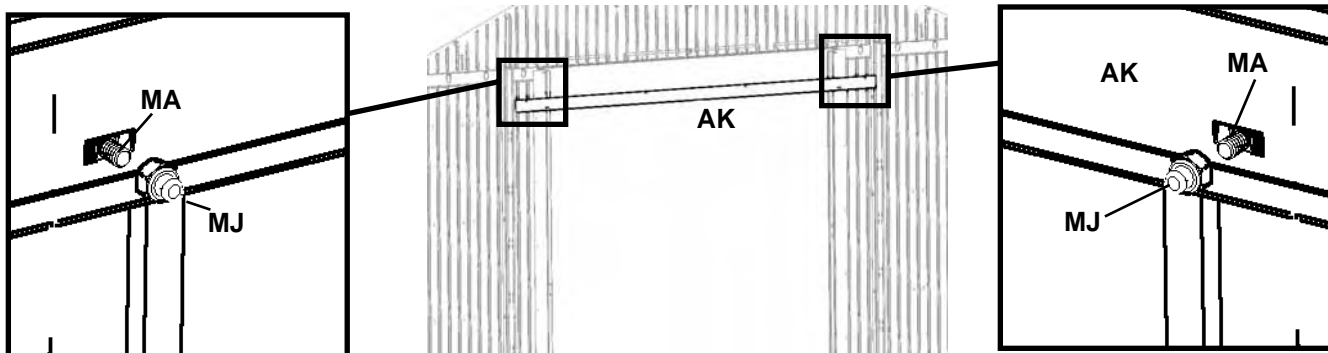

19d Screw the Door Frame Floor Brackets (at the bottom of each hinge) to the floor. Insert the remaining screws into the Door Hinges.

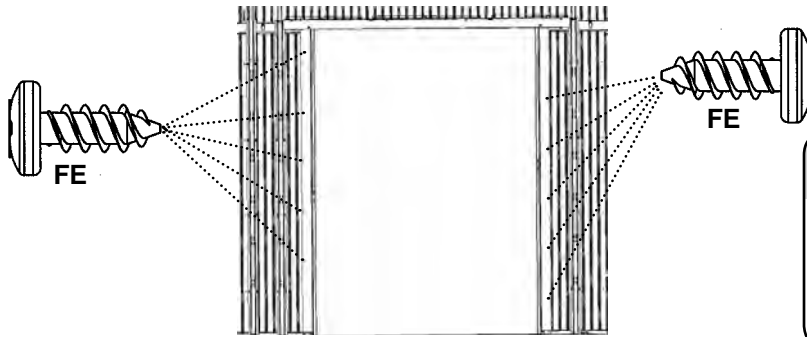
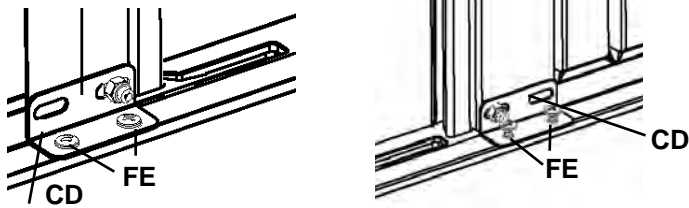

Step 19 Hardware (continued)

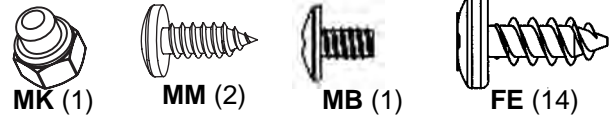

Hardware Bags: 1012086, 1009126 Screwdriver

⚠ WARNING ⚠

Do not overtighten the Cap Nut. If the end of the Bolt breaks through the plastic cap, call our Customer Service Department at the number on Page One. Exposed threads on the end of the Bolt may cause serious injuries.

19e Install a Gable Truss Brace (BD) between the front truss and the Gable. Screw the Gable Truss Brace (BD) into the Door Header Channel.

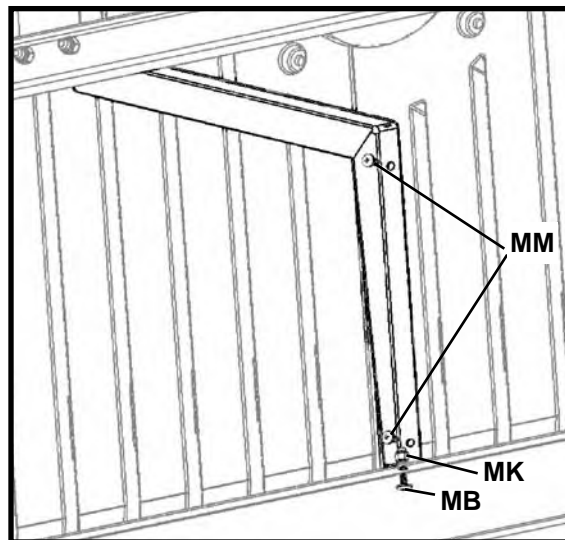
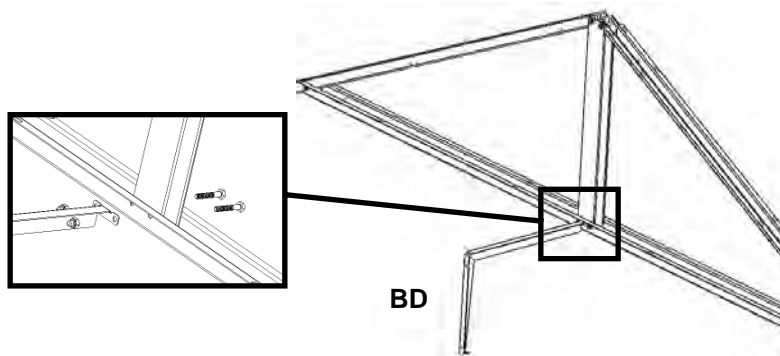

There are no pilot holes in the Gable to receive the Screws (MM). Insert them directly into the plastic.

⚠ WARNING ⚠
Look for overhead power lines before climbing ladders, or lifting shed parts over your head. Failure to do so may result in electrical shock or other serious injury or death.

Step 19 Hardware (continued)

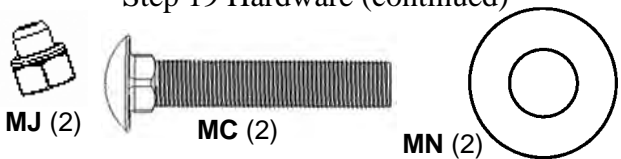

MJ (2) **MC (2)** **MN (2)**

Hardware Bags: 1012086 Screwdriver, 7/16" Wrench

19f Lift and slide Left Door onto Hinge.

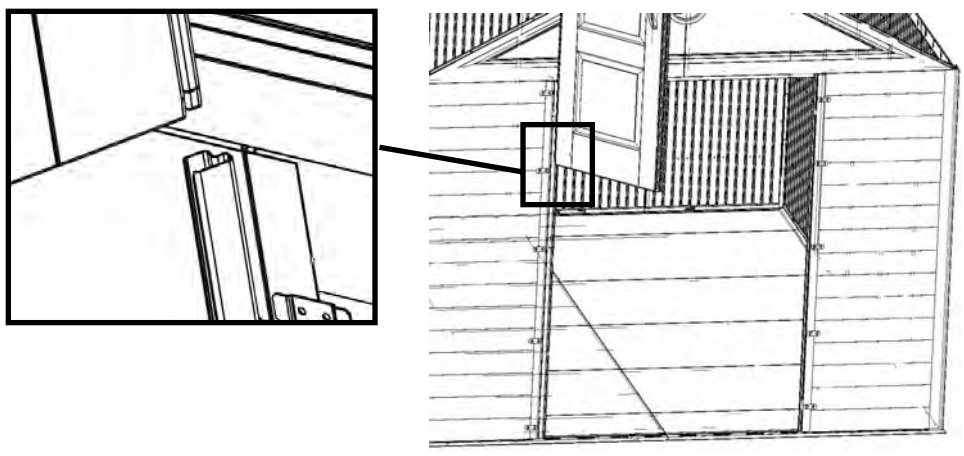

19g Secure with a 1/4" x 1 1/2" Bolt (MC), 1/4" Washers (MN) and 1/4" Cap Nuts (MJ).

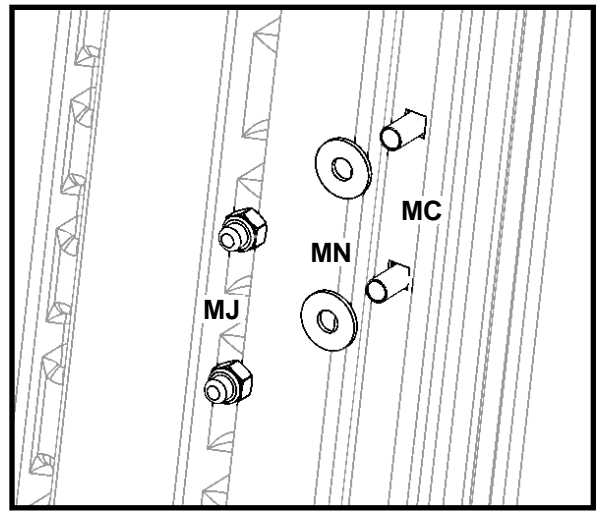

Put Washers (MN) and Cap Nuts (MJ) on Bolts (MC).

⚠ WARNING ⚠
Do not overtighten the Cap Nut. If the end of the Bolt breaks through the plastic cap, call our Customer Service Department at the number on Page One. Exposed threads on the end of the Bolt may cause serious injuries.

Step 19 Hardware (continued)

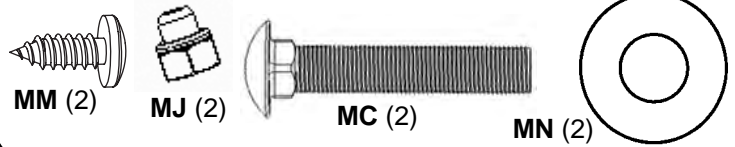

Hardware Bags: 1012086 Screwdriver, 7/16" Wrench

19h Lift and slide Right Door onto Hinge and secure with a 1/4" x 1 1/2" Bolt (MC), 1/4" Washers (MN) and 1/4" Cap Nuts (MJ).

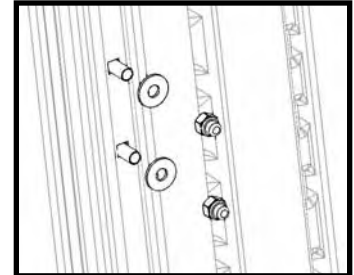
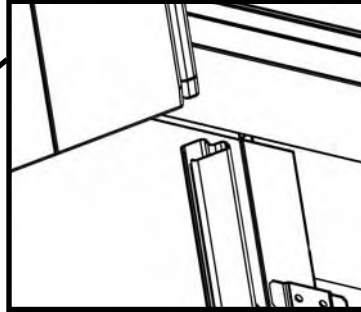
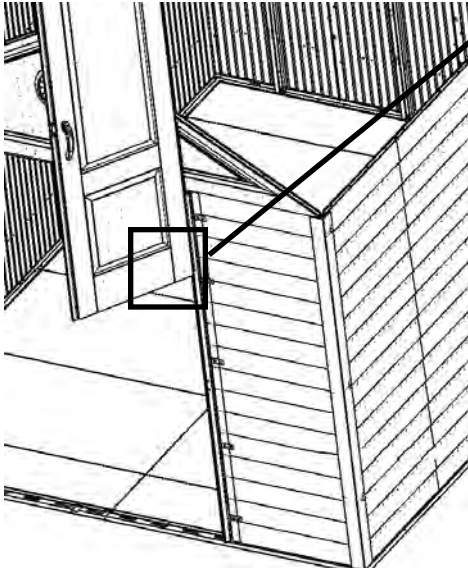

Put Washers (MN) and Cap Nuts (MJ) on Bolts (MC).



There may be uneven spacing between and around the doors at this stage of assembly. This is normally resolved as you complete the remaining assembly steps. If, after assembly, the spacing is still uneven, see the "Adjust Door Spacing" step at the end of this manual.

Assembly Tip #8

Door Hinge Alignment

Use this tip if the shed doors will not close or latch completely:

- 1. Open the door that won't close.*
- 2. Apply downward pressure on the door (next to the hinge) by either hanging on the door or tapping with a rubber mallet (place a piece of wood between the mallet and the door to avoid damage to the door).*

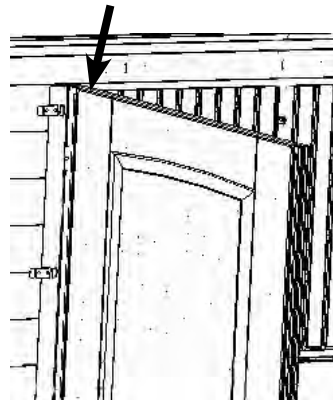

19i Screw the Deadbolt Strike Plate (CJ) into place in the doorway with #10 x 1/2" Screws (MM).

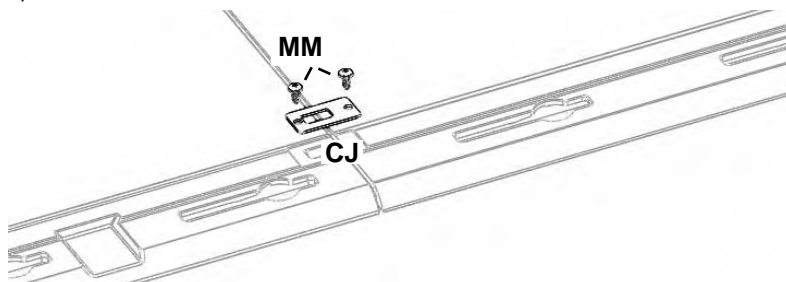

Assembly Tip #9

Install Rear Wall Supports

Use the holes in column #2

Each Wall Panel has three columns of holes. The Wall Supports are to be attached to the second column of holes on each wall panel of the back wall.

20 Assemble & Install Rear Wall Supports

Step 20 Hardware

FE (32) **FB (8)** **MJ (8)**

Hardware Bag: 1013052, 1009126, 1011135, 1013053 or 1011614 **Screwdriver, 7/16" Wrench**

BUILD TWO LONG SUPPORTS:

20a Attach a Long Vertical Extension Channel (AE) to a Wall Support Channel (AA). Repeat for another Wall Support

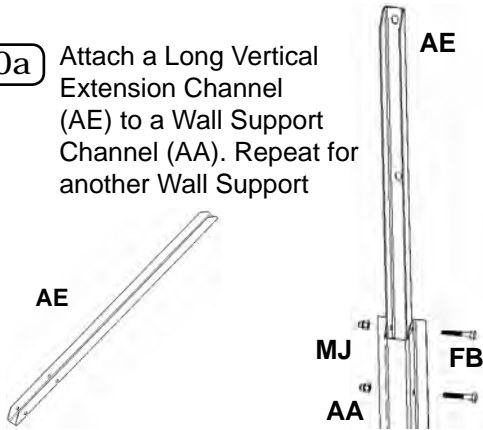

BUILD TWO SHORTER SUPPORTS:

20b Attach a Short Vertical Extension Channel (AJ) to a Wall Support Channel (AA). Make Sure the Extension Channel is installed in the correct direction. Repeat for another Wall Support.

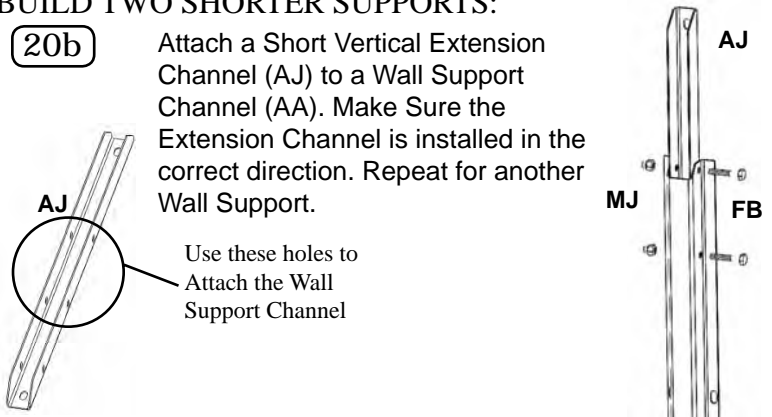

20c Install Wall Supports to Rear Wall. Position the shorter Supports with Channels (AJ) at the far left and far right Wall Panels (**See Assembly Tip #9 above**). The long Supports with Extensions (AE) are placed in the middle positions. Do not completely tighten the screws until after the Rear Gable is installed.

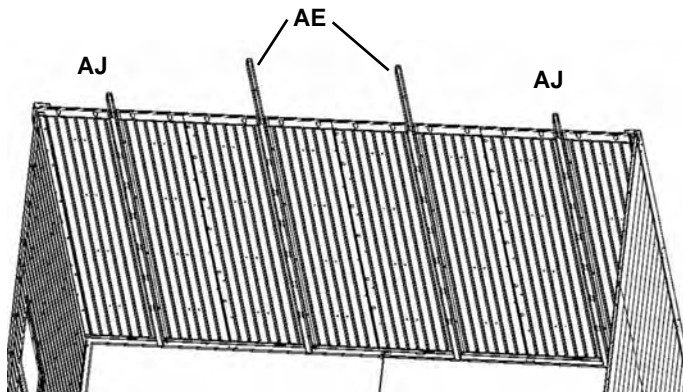

⚠ WARNING ⚠

Do not overtighten the Cap Nut. If the end of the Bolt breaks through the plastic cap, call our Customer Service Department at the number on Page One. Exposed threads on the end of the Bolt may cause serious injuries.

21 Install Rear Gable

- 21a Install Rear Gable. Screw the Gable to the wall and to all four Vertical Extension Channels (AJ & AE).

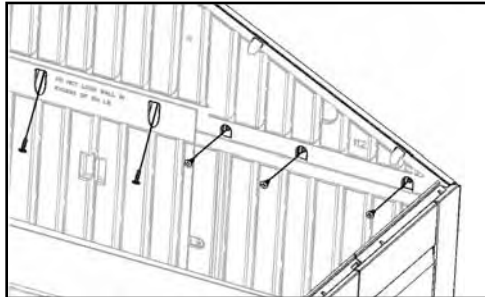
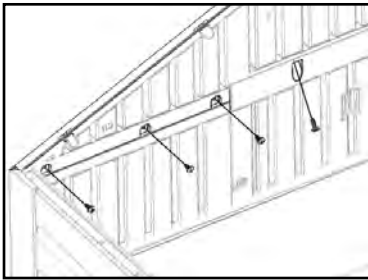

Step 21 Hardware

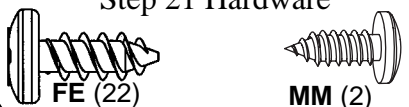

FE (22) MM (2)

Hardware Bags: 1011135, 1012086
Screwdriver

Tighten the Screws on the Wall Supports after the Gable is installed.

- 21b Install Gable Truss Brace (BD) between last truss and the Rear Gable. Connect the Brace to the Gable with two #10 x 1/2" Screws (MM)

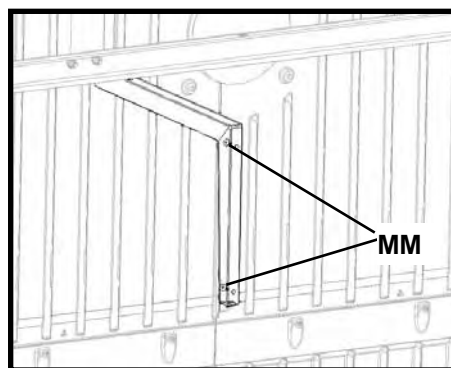
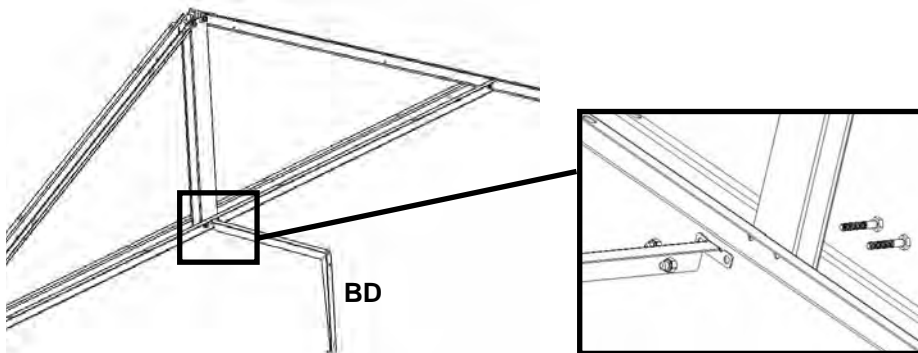

There are no pilot holes in the Gable to receive the Screws (MM). Insert them directly into the plastic.

Assembly Tip #10

Connect Outer Roof Panels to the Gable and Truss

Note: You may need to apply pressure to walls or roof panels to get screw pilot holes to line up.

1. *Line-up slots in gable with holes in the Outside Roof Panel. Do not insert screws into any slot unless you can see the pilot hole behind the slot.*

****2.** *Starting at the top of the Gable, screw the Panel to the Gable.***

-Do Not Completely tighten the screws until all are in place.-

3. *Starting at the top of the Panel, screw the Panel to the Truss.*

4. *Fit the top of the wall into the groove at the bottom of the Roof Panel. Attach with screws.*

①

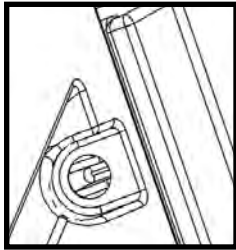

②

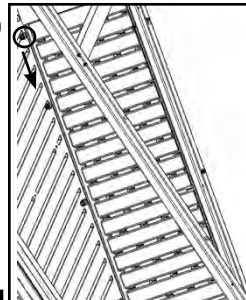

③

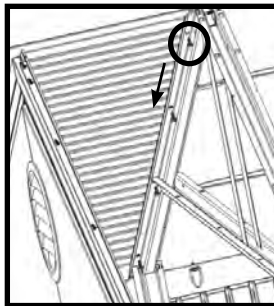

④

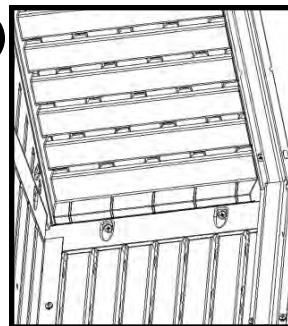

22 Install Front Roof Section

22a

Install Outer Roof Panels A & B (AC & AG) at the front of the shed. Always start inserting screws at the top of the Roof Panel. **See Assembly Tip #10 (above).**

Step 22 Hardware

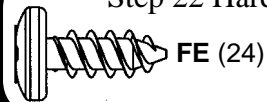

Hardware Bags: 1011135
Screwdriver

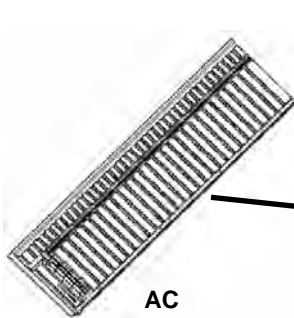

AC

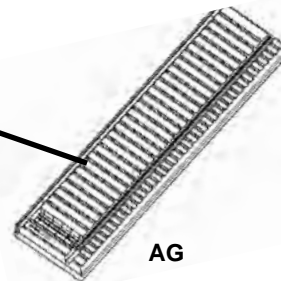
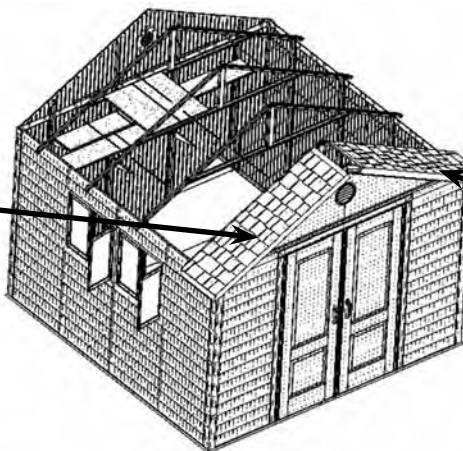

AG

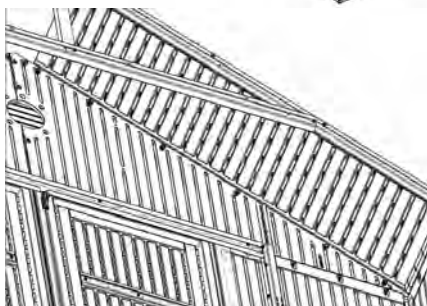

Note: This is an interior upward view.

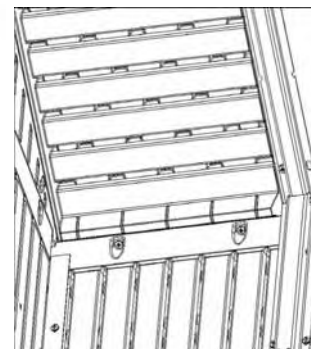

Note: This is an interior upward view.

22b Fold End Roof Cap (AQ) along its hinge. Install it at the front of the shed.

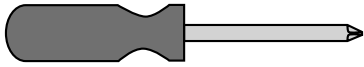

Only use a hand screwdriver on this step

Step 22 Hardware (Cont.)

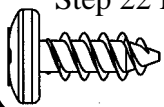

FE (6)

Hardware Bags: 1011135
Screwdriver

Note: This is an exterior view.

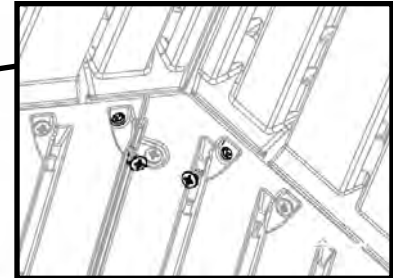
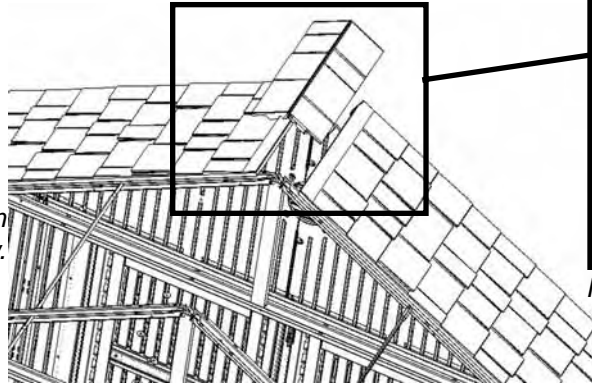

Note: This is an interior upward view.

22c Install a Roof Cap Cover (AW)

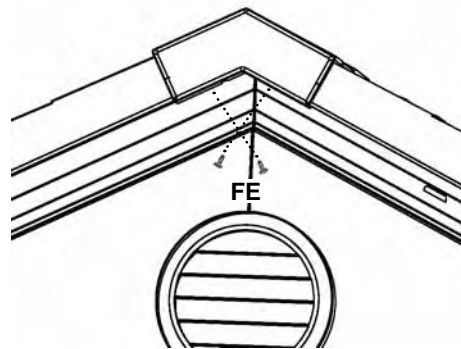
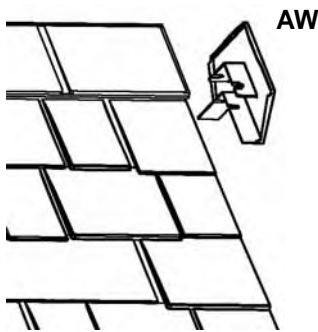

23 Install Center Roof Sections

23a Install the next two Inner Roof Panels (JE) on the left and right side of the shed. Insert two Roof Support Strips (JK) into notches on each panel before screwing into place. **See Assembly Tip #11 (pg. 38).**

Step 23 Hardware (pp.37-38)

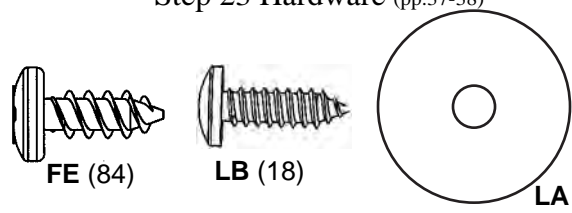

FE (84) **LB (18)** **LA (18)**

Hardware Bags: 1011135, 1010047, 1011616
Screwdriver

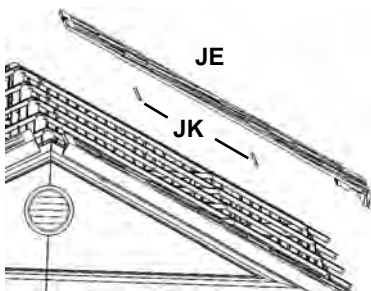

Fit two Roof Support Strips (JK) into the Inner Roof Panel (JE) as you put it in place.

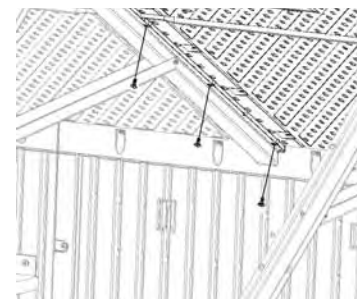
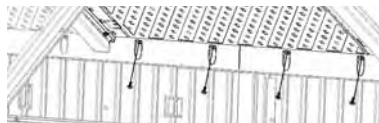

23b Install a Center Roof Cap (JA) with 1/4" x 5/8" Screws (FE) and a Skylight (JG) with #10 x 5/8" Screws (LB) and #10 Washers (LA) to the Roof Panels.

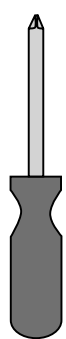
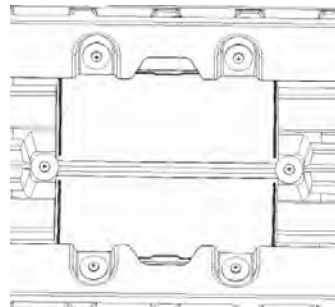
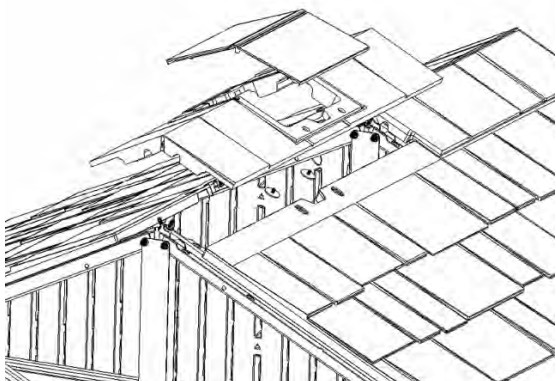

Attach Skylight with #10 Washers (LA) and #10 x 5/8" Screws (LB).

Only use a hand screwdriver for the Skylights

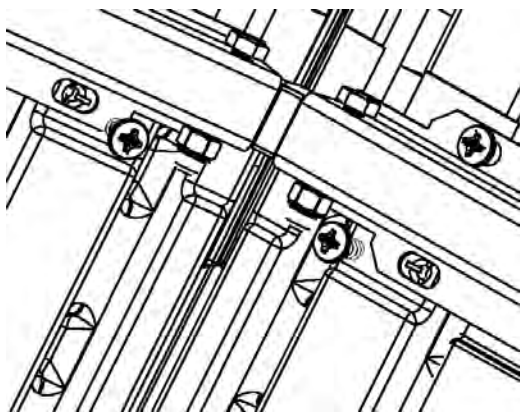

Attach Roof Cap (JA) to Truss on both sides with 1/4" x 5/8" Screws (FE).

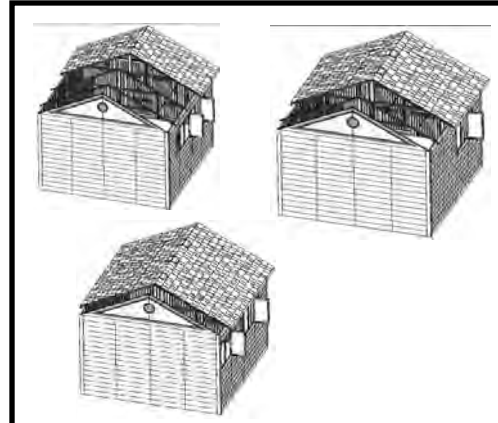

Repeat Step 23 for all three center roof sections.

Assembly Tip #11

Connect Inner Roof Panels to the Truss

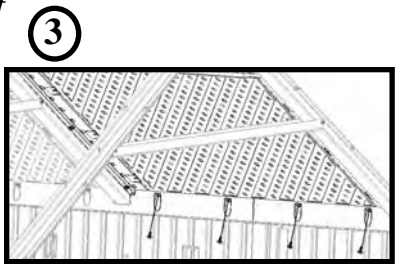
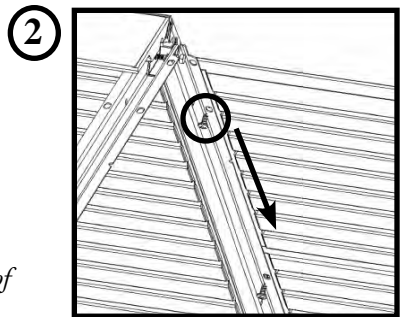
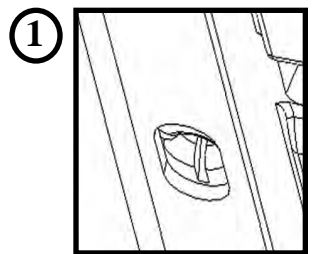

Note: You may need to apply pressure to walls or roof panels to get screw pilot holes to line up.

1. Line-up slots in Truss with holes in the Inner Roof Panel. Do not insert screws into any slot unless you can see the pilot hole behind the slot.

****2.** Starting at the top of the front edge of the Panel, screw the Panel to the Truss. Repeat for the back edge of the Panel. **

3. Fit the top of the wall into the groove at the bottom of the Roof Panel. Attach with screws.

24 Install Rear Roof Section

24a Position the Outer Roof Panel A (AC) and secure to Gable and Truss. Repeat on the other side with Outer Roof Panel B (AG). See Assembly Tip #10 (p. 36).

Step 24 Hardware

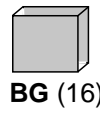
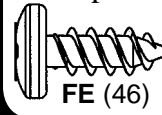

Hardware Bags: 1011135, 1016071, 1011615
Screwdriver

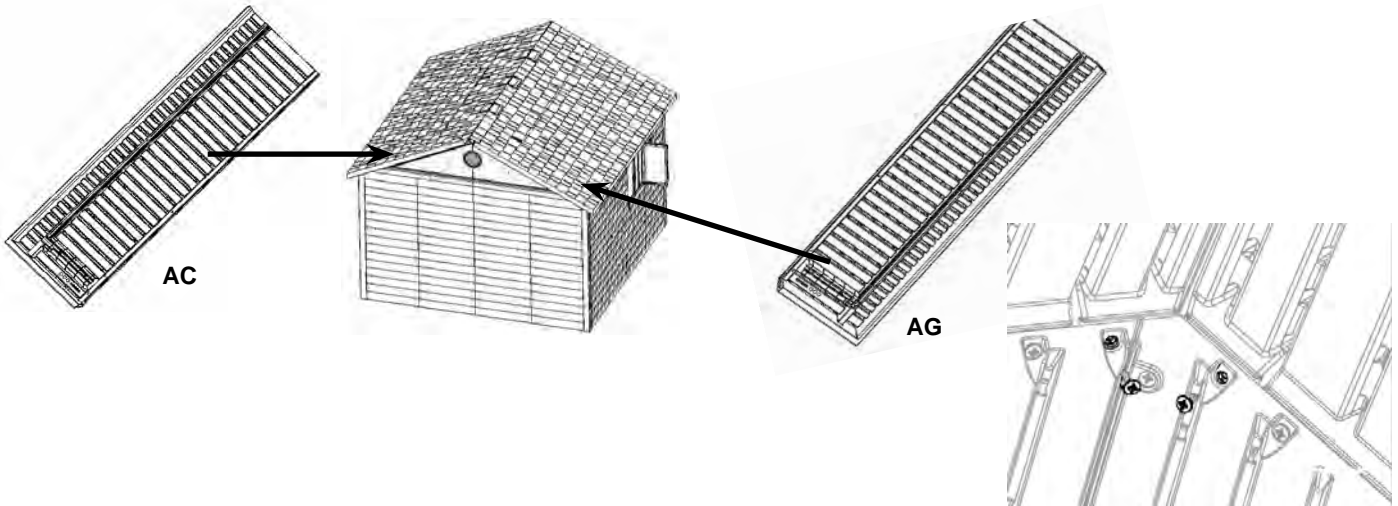

24b Install a Roof Cap Cover (AW) at the back of the Shed.

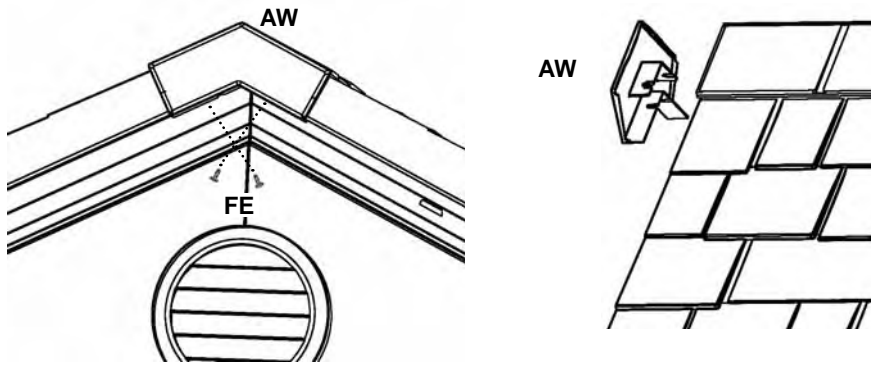

24c Along the outside edges of the shed, Fasten the Trusses to the underside of the Roof Panels (Fig. 1). Insert two Foam Cubes (BG) at each truss location (Fig. 2).

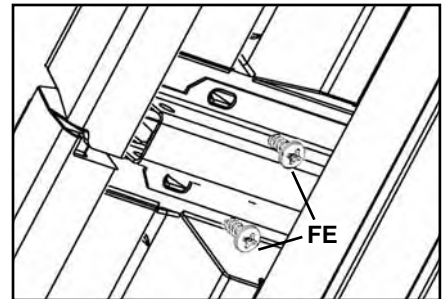
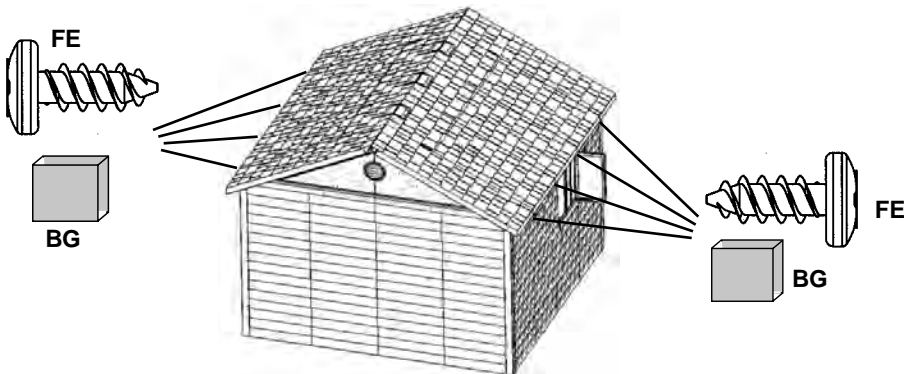

Fig. 1

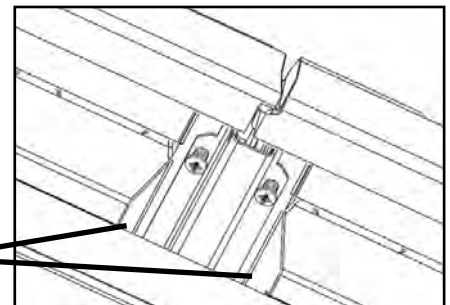

Fig. 2

25 Shelf Installation

- 25a Insert Shelf Brackets (BE and BF) into notches in any Wall Support Channel. Place the Shelves on brackets and secure with #10 Screws (MM) and #10 Washers (MP). Use the 14" Shelf Brackets with 14" shelves, and 10" Brackets with 10" shelves.

Step 23 Hardware



MM (49)

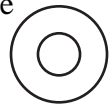

MP (28)

Hardware Bags: 1009125
Screwdriver

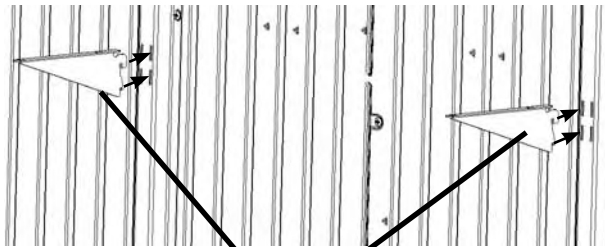

BE or BF

Insert Brackets into the inside set of slots on the Wall Channels. Otherwise Brackets will be too far apart to support shelves.

There are no pilot holes on the bottom of the shelf, screws are inserted directly into the plastic.

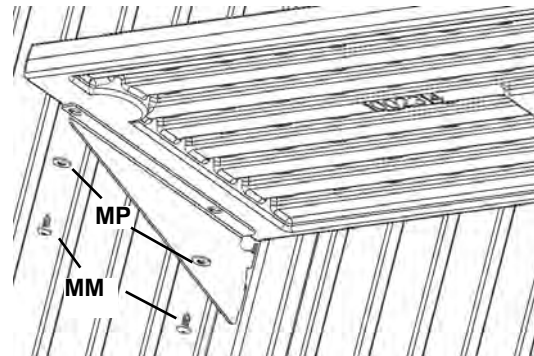

- 25b Install a Back Shelf Bracket (EB) to any 10" or 14" Shelf with a #10 Screw (MM). Line up the Bracket so that it will connect to the wall in between grooves. Attach it to the bottom of the shelf. Then screw the Bracket into the wall.

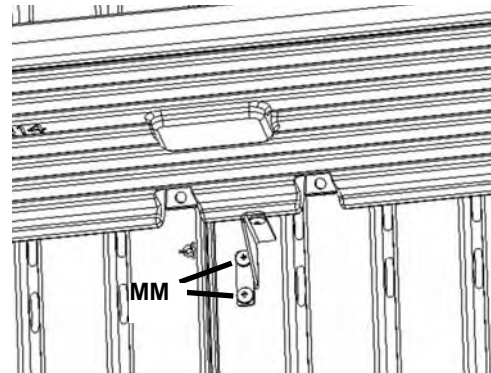
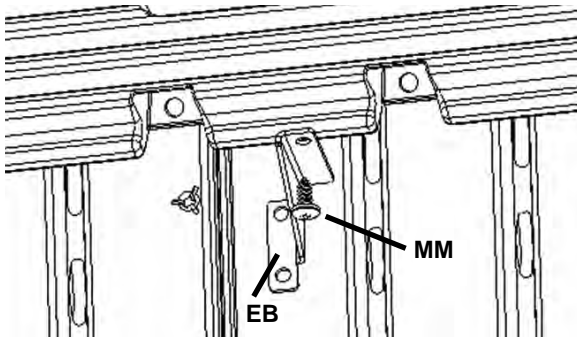

Alternate Shelf Location

- 25c Shelves may also be installed in between trusses to provide overhead storage. Rest a shelf (either 10" or 14") between two trusses. Attach shelf to Truss Channels (AM) through slotted holes in channels.

The shelves fit length wise inbetween the Trusses.

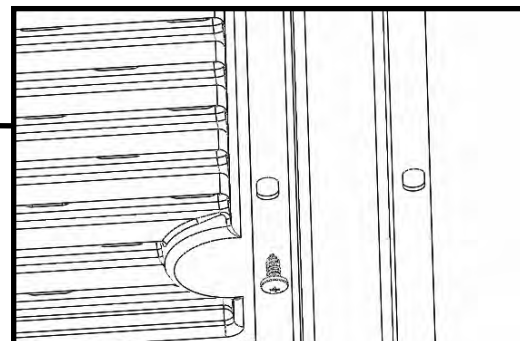
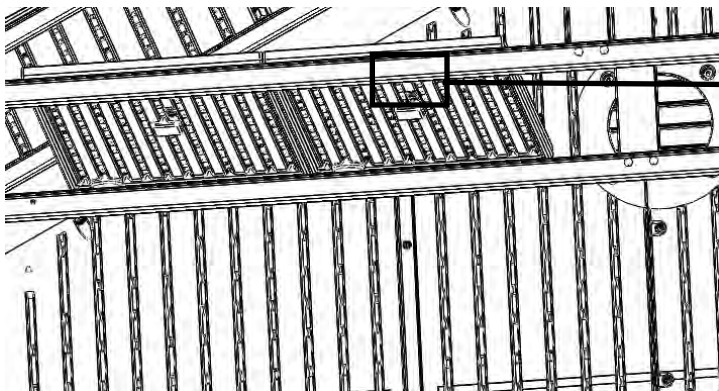

Note: This is an interior upward view.

26 Pegboard Installation

- 26a Use a Level, and position both 16" Pegboard Strips (BA) in the desired locations. Screw the Pegboards to the wall using #10 x 3/4" Screws (ML). **See Note.**

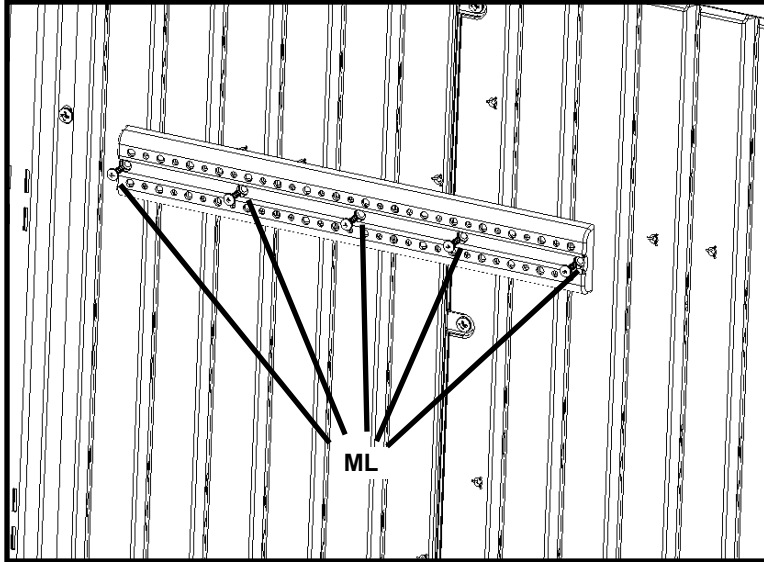

Step 26 Hardware

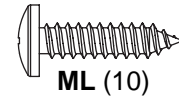

ML (10)

Hardware Bags: 1012088
Screwdriver, Level



The Pegboard Strips are screwed directly into the plastic. Line up Strip anywhere on wall so that holes are over plastic (and not over a groove in the wall).

Be sure that the Pegboard Strip is level before inserting screws.



27 Anchoring the Shed

- 27a After assembling your shed, you may want to anchor it to the ground. It can be anchored through the Floor Brackets (FA) you attached to each Wall Support. Consult your local hardware store for suggestions on the best hardware to use for anchoring your shed. Whatever you use, the diameter of any screw or bolt cannot exceed 3/8".

Insert Anchoring Hardware through the Floor Brackets (FA) attached to the bottom of each Wall Support.

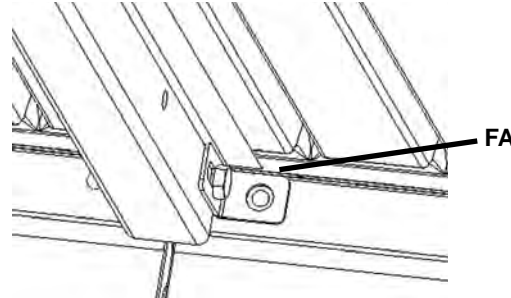

28 Adjust Door Spacing

- 28a You may need to move the tops and/or bottoms of the doors to eliminate uneven gaps. Loosen the Carriage Bolts at the four corners of the door frame. Loosen all screws in the left and right Door Hinges by a half a turn. Move Doors until gaps are even. Re-tighten the four Carriage Bolts. Re-tighten the screws in the left and right Door Hinges.

Loosen the Screws in both Hinges before adjusting Doors.

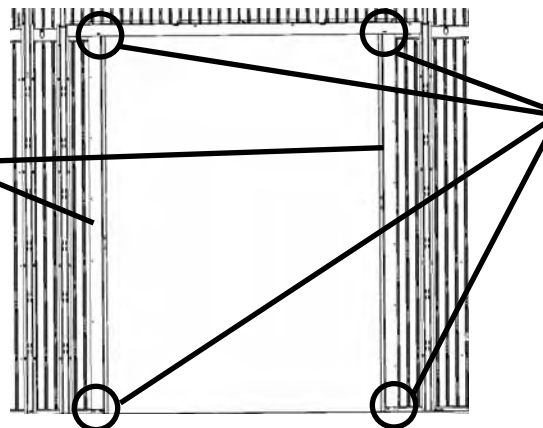

Loosen these Carriage Bolts before adjusting Doors.

29 Attach Door Trim

29a Slide Side Door Trim into place onto door hinge brackets.

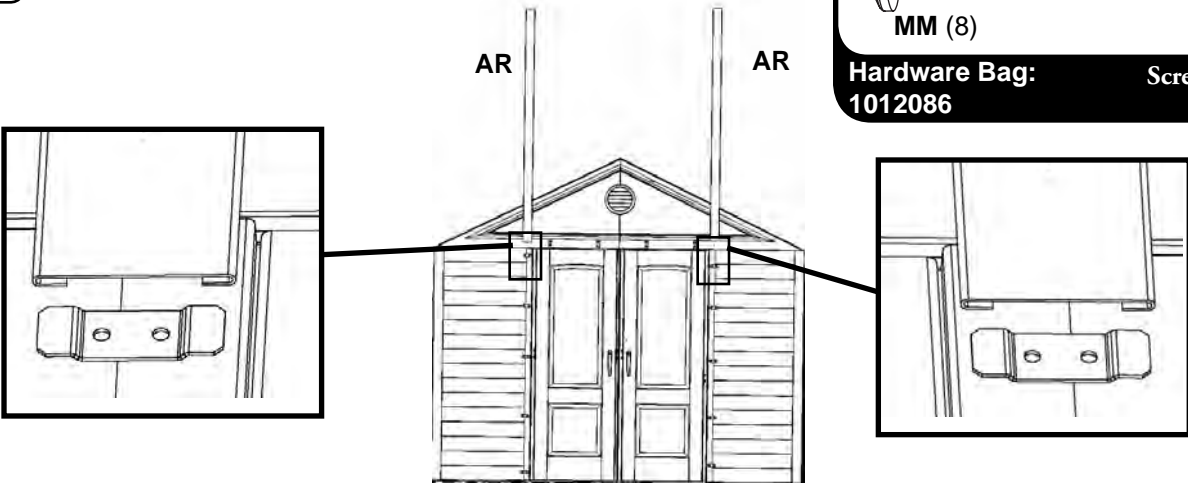

Step 29 Hardware



MM (8)

Hardware Bag:
1012086

Screwdriver

29b Attach four Door Trim Brackets (CE) above the door frame.

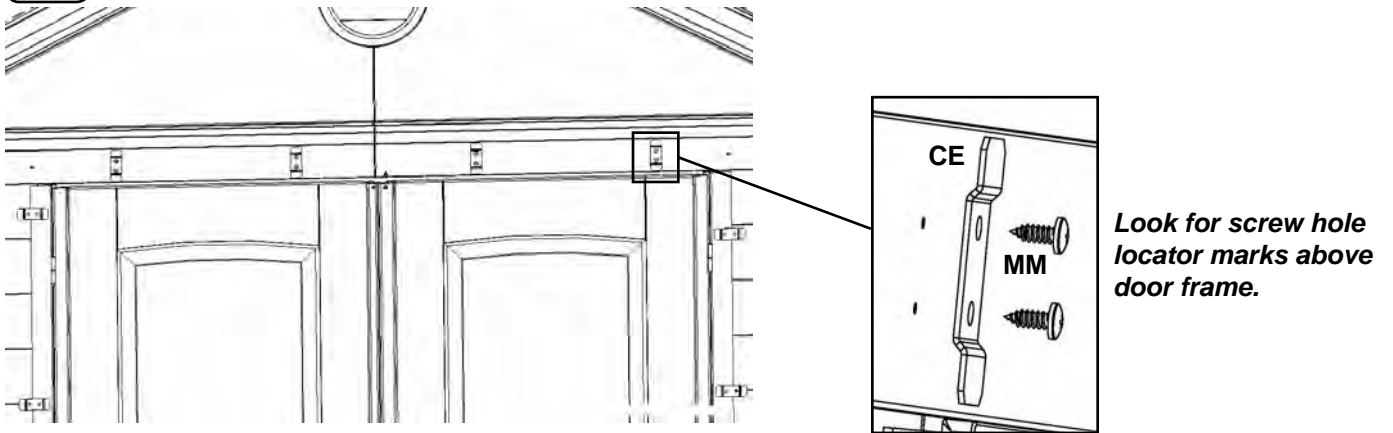

29c Slide Door Trim Clips (CK) into the top of the Side Door Trim (AR) (Fig. 1), on each side of the door. Slide the Top Door Trim (AS) into place, and Secure with the Door Trim Clips (Fig. 2).

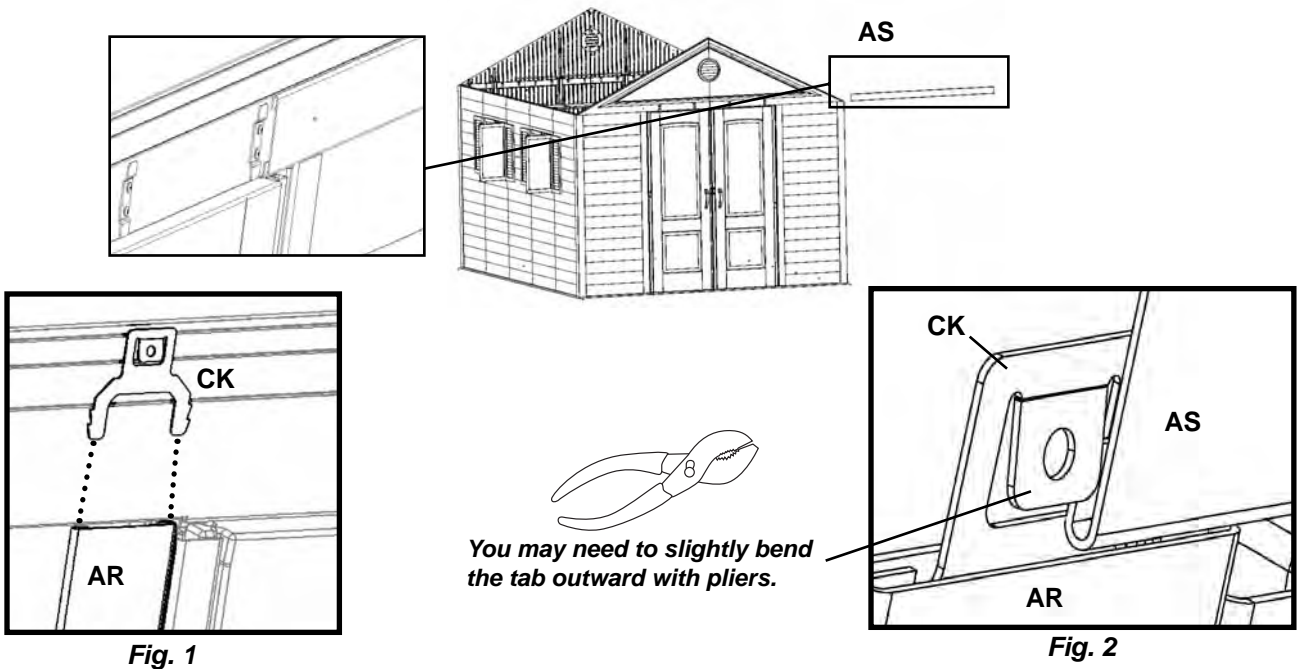

Enhance your Lifetime® Outdoor Shed by purchasing the following Shed Accessories:

- | | |
|---------|---|
| Model # | |
| 0111 | Window Shutters
Two decorative window shutters. |
| 0112 | Shed Lights (2 pack)
Two battery powered Touch Lights. |
| 0113 | 16" Pegboard Strips w/ hardware
Two sixteen inch Pegboard Strips with hooks. Great for hanging large items such as: rakes, shovels, or other tools. |
| 0114 | 10" Shelf Kit w/ hardware (5 pack)
Five 30" x 10" Shelves with hardware. |
| 0115 | 14" Shelf Kit w/ hardware (5 pack)
Five 30" x 14" Shelves with hardware. |
| 6426 | 60" Shed Extension Kit w/ 2 windows
Extend your shed five feet for the ultimate storage building. |

**To purchase shed accessories,
visit us at:
www.buylifetime.com**

**Or call:
1 (800) 424-3865**

Congratulations on your Lifetime® Outdoor Shed purchase. By following the instructions below, your new Lifetime shed should provide you with years of service and enjoyment.

Cleaning and Care

The polyethylene walls and shelves are stain- and solvent resistant. To clean, use a mild soap and a soft-bristled brush. Abrasive cleaning materials may scratch the plastic and are not recommended. Repair scratches or rust spots on the metal by Sanding the affected area lightly; using a rust preventative spray primer; and finally, spraying with a high-gloss spray enamel paint. Avoid placing a direct heat source on or near surfaces unless using a heat barrier.

**For warranty details or to register your product, visit
www.lifetime.com or call 801-776-1532**

LIFETIME OUTDOOR SHED EQUIPMENT

10-YEAR LIMITED FACTORY WARRANTY

THE MANUFACTURER RESERVES THE RIGHT TO MAKE SUBSTITUTIONS TO WARRANTY CLAIMS IF PARTS ARE UNAVAILABLE OR OBSOLETE.

1. Lifetime outdoor sheds are warranted to the original purchaser to be free from defects in material or workmanship for a period of ten years from the date of original retail purchase. The word "defects" is defined as imperfections that impair the use of the product. Defects resulting from misuse, abuse or negligence will void this warranty. This warranty does not cover defects due to improper installation, alteration or accident. This warranty does not cover damage caused by vandalism, rusting, "acts of nature" or any other event beyond the control of the manufacturer.
2. This warranty is nontransferable and is expressly limited to the repair or replacement of defective product. If the product is defective within the terms of this warranty, Lifetime Products, Inc. will repair or replace defective parts at no cost to the purchaser. Shipping charges to and from the factory are not covered and are the responsibility of the purchaser. Labor charges and related expenses for removal, installation or replacement of the shed or its components are not covered under this warranty.
3. This warranty does not cover scratching or scuffing of the product that may result from normal usage. In addition, defects resulting from intentional damage, negligence, unreasonable use or hanging from the truss will void this warranty.
4. Liability for incidental or consequential damages is excluded to the extent permitted by law. While every attempt is made to embody the highest degree of safety in all equipment, freedom from injury cannot be guaranteed. The user assumes all risk of injury resulting from the use of this product. All merchandise is sold on this condition, and no representative of the company may waive or change this policy.
5. This warranty is expressly in lieu of all other warranties, expressed or implied, including warranties of merchantability or fitness for use. Neither Lifetime Products, Inc., nor any representative assumes any other liability in connection with this product.

ALL WARRANTY CLAIMS MUST BE ACCOMPANIED BY A SALES RECEIPT.

REPORT PRODUCT DEFECTS IN WRITING TO:

Lifetime Products, Inc., PO Box 160010 Clearfield, UT 84016-0010
or call (800) 225-3865 M-F 8 a.m. to 5 p.m. MST.

Please include your dated sales receipt and photographs of damaged parts.

To register the product, visit our web site at www.lifetime.com



www.lifetime.com

©2004 Lifetime Products, Inc.

PO Box 160010 • Freeport Center, Bldg. D-11 Clearfield, Utah 84016-0010
T: 800-225-3865 • F: 801-728-1907