

# STANDERS – LEVER EXTENDER #3000

## Assembly Instructions:

### Parts List:

1. One (1) Handle
2. One (1) Bracket
3. One (1) Allen Wrench
4. Four (4) Bolts

### Instructions:

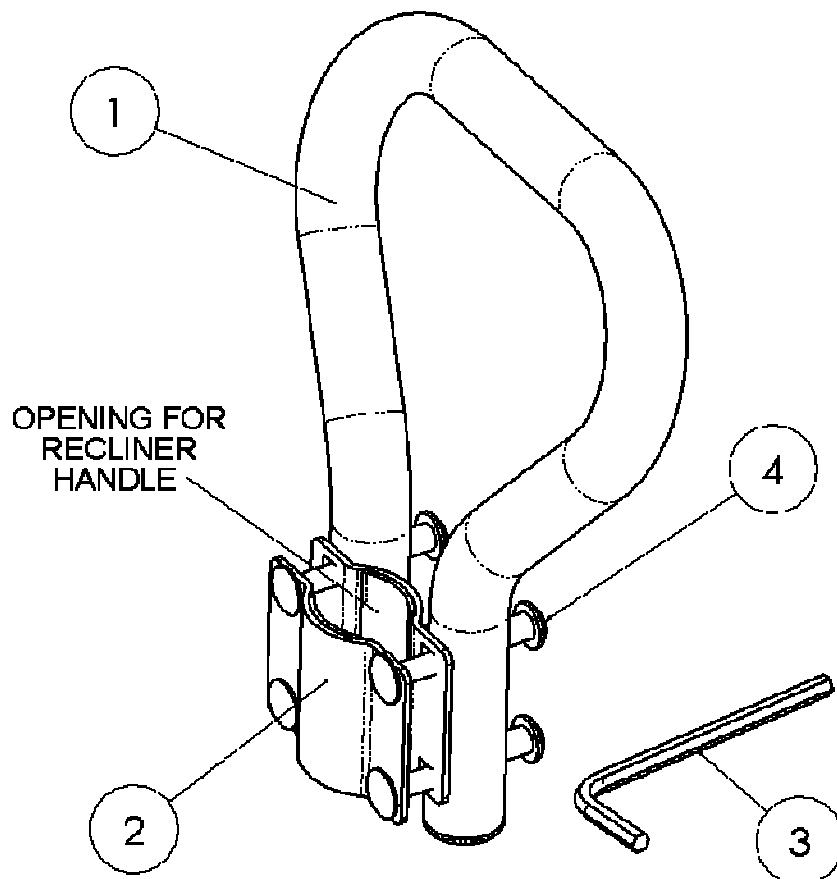

1. Loosen the four Bolts (Item-4) using Allen Wrench (Item-3) to allow Handle (Item-1) and Bracket (Item-2) to move apart from each other. This will create an opening between the Handle (Item 1) and the Bracket (Item-2). **Note: Just loosen the bolts, do not take bolts completely out.**
2. Place your furniture recliner handle into the opening and tighten the four Bolts (Item 4) with Allen Wrench (Item 3) until the Handle (Item-1) and the Bracket (Item 2) provide a secure clamp on your furniture recliner handle.

Note: Foam pads located on the Handle (Item 1) and Bracket (Item 2) will provide protection from scratching your recliner handle.

Visit Our Website at [www.stander.com](http://www.stander.com) to view additional Standers Products, or call us at 1-800-506-9901 for a free brochure.  
**THANK YOU FOR CHOOSING STANDERS' PRODUCT!**

Standers is committed to providing affordable products that exceed the customers expectations of function and value. We are developing new products that make daily living more enjoyable. You may visit our website at [www.stander.com](http://www.stander.com) to see new products, or you may email or call us at [sales@stander.com](mailto:sales@stander.com) (1-800-506-9901) for a color brochure.

### **WARNING**

1. Product instructions must be carefully followed to ensure that the product is properly assembled and positioned. Failure to follow the instructions could result in damage to furniture or serious injury to the user(s) of the product.
2. Children should not be allowed to play or pull on the Extender #3000. Improper pulling or playing with the Extender #3000 may result in a broken recliner handle.
3. The Extender #3000 must be positioned on the recliner handle so that the handle and bracket provide adequate clamping to the recliner handle.
4. **DISCLAIMER:** Neither Standers, Inc. nor the manufacture is liable for any harm, injury, or damage that may result or has resulted from the improper use or assembly of the product.

### **LIMITED WARRANTY**

Congratulations on your purchase of your Standers brand product. Please read the following warranty statement for your protection.

Standers, Inc. warrants to the original purchaser that this product will be free from defects in material and/or workmanship for 3 months from the date of purchase. During the warranty period, Standers, Inc. will correct any defects in material or workmanship, at no charge. Shipping cost, however, must be prepaid by the original purchaser. Any replacement parts will be new and are warranted for the remainder of the original warranty or thirty (30) days from the date of shipment, whichever is longer. The original purchaser must notify Standers, Inc. during the warranty period in writing of the defect in workmanship or material. This warranty is not transferable and covers only normal use. **NO SHIPPING CHARGES ARE REFUNDABLE.**

This warranty does NOT cover the following:

1. Damage during shipment other than original shipment to retailer.
2. Damage caused by unauthorized attachments, alterations, or modifications.
3. Damage caused by the use of the product for purposes other than those for which the product was designed or intended.
4. Damage caused by any other abuse, misuse, mishandling or misapplication.

Under no circumstances shall Standers, Inc. be liable for any special, incidental, or consequential damages base upon breach of this limited warranty, breach or contract, or strict liability.

**THERE ARE NO WARRANTIES WHICH EXTEND BEYOND THE DESCRIPTION ON THE FACE HEREOF. ALL OTHER WARRANTIES, EXPRESS OR IMPLIED (INCLUDING ALL IMPLIED WARRANTIES OF MERCHANTABILITY OR FITNESS FOR A PARTICULAR PURPOSE), ARE HEREBY DISCLAIMED.**

Some states do not allow limitations on how long an implied warranty lasts, so the above limitations may not apply to you. This warranty gives you specific legal rights, and you may also have other rights which vary from state to state.

To obtain service under this warranty, you can reach Standers, Inc. at 1-800-506-9901 or email us at [sales@stander.com](mailto:sales@stander.com). You can also visit our website at [www.stander.com](http://www.stander.com).